

# Aero H



colour included  
in the price



**Aero H** 410↓ × 1800↔ SX  
colour: RAL 3020

3-axis thermostatic valve set, left, chrome  
Pipe-masking set, chrome



# Aero H



 colour included  
in the price

Design: Jacek Ryń

## Standard connection:

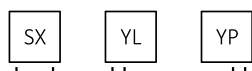

## Optional connection:

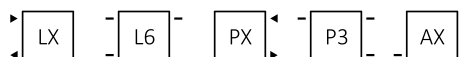

## Available sizes:

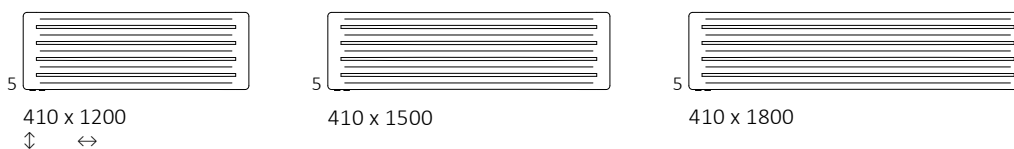
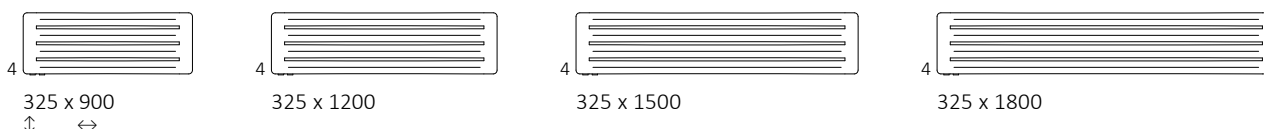

## Specification:

Working pressure: 700 kPa    Maximum operating temperature: 95°C

A ↓ [mm]	B ↔ [mm]	C1 [mm]	C2 [mm]	75/65/20°C [W]	55/45/20°C [W]	D [mm]	E [mm]	F [mm]	H [dm³]	⚖️ [kg]	Product code <small>Configuration code p. 5</small>
325	900	50	830	290	160	830	170	77,5	3,25	8,97	WGARH032090
325	1200	50	1130	388	214	1130	170	77,5	4,57	11,88	WGARH032120
325	1500	50	1430	485	267	1430	170	77,5	5,90	14,79	WGARH032150
325	1800	50	1730	582	320	1730	170	77,5	7,22	17,70	WGARH032180
410	1200	50	1130	480	265	1130	255	77,5	5,72	14,87	WGARH041120
410	1500	50	1430	600	330	1430	255	77,5	7,37	18,51	WGARH041150
410	1800	50	1730	720	396	1730	255	77,5	9,03	22,15	WGARH041180



## Technical drawing:

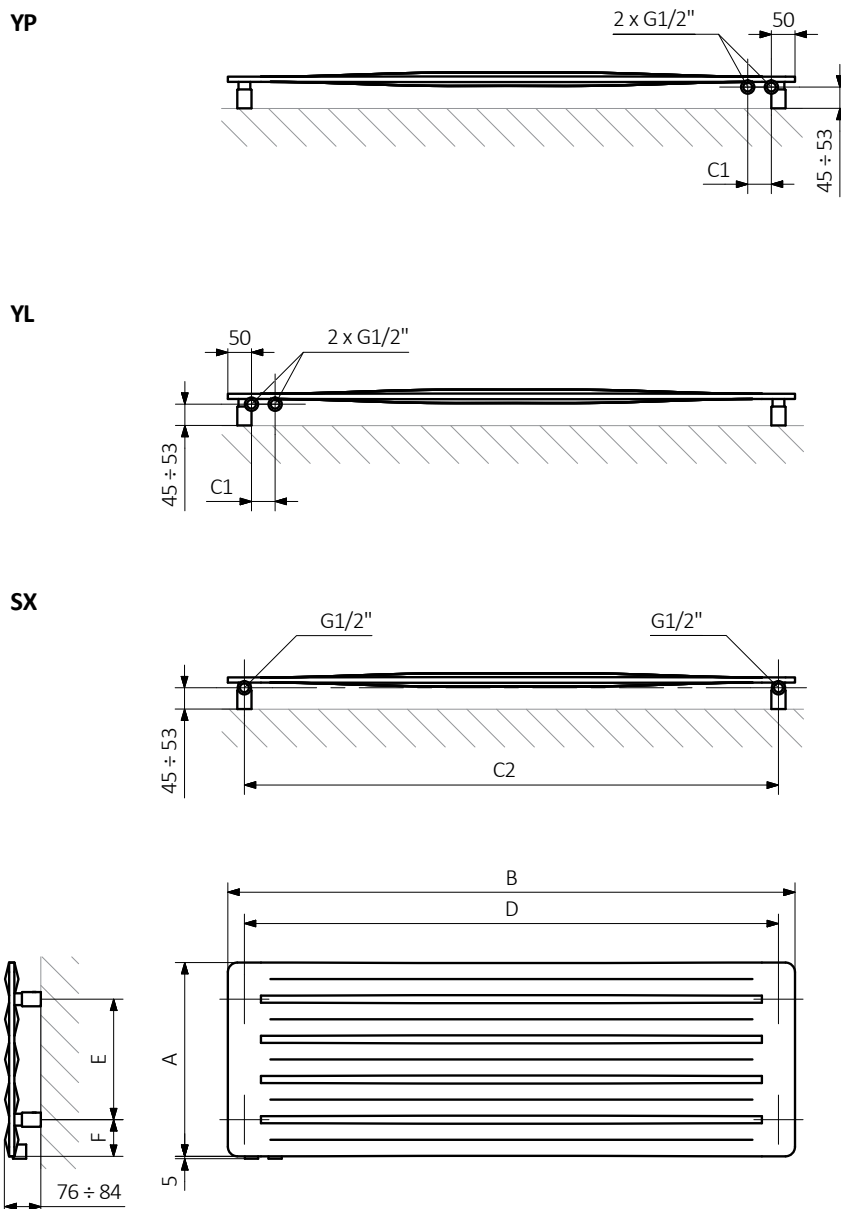

A – Height B – Width C1-C5 – Distance between pipe centres D – Horizontal distance between mounting bracket centres  
E – Vertical distance between mounting brackets F – Distance between a mounting bracket and the bottom of the radiator

### Pipe:

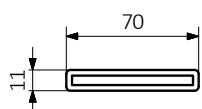



In the table with technical data, the last column lists product codes. When placing an order, please remember to quote the product code followed by the configuration code as shown in the diagram below:

## The construction of a water and dual fuel radiator product and configuration code

WGARH032090

K916SX

PRODUCT CODE

(located in the table for the product)

CONFIGURATION CODE

(supplemented by hand)

### Example Configuration

K 916 SX

Package code

*K - carton box*

Colour code

Connection code

### Epoxy primer

**E** – Code of epoxy primer is an extra processes.

WGARH032090 K916SX **E** — *Extraprocessesoradditionscode*

# Aero H



colour included  
in the price

## Legend



Radiator available in a "water" version.



Radiator suitable for dual fuel connection. Electric heating element can be installed.



Radiator available in electric only version. It comes prefilled with a 'heating medium' and equipped with a heating element. All tested and ready to use.



Connection types dedicated for this radiator. The icon shows the flow and return connections for the radiator as well as the thermostatic valve and heating element position if applicable.



Suggested heating element power output for electric and dual fuel versions.



Weight.



Capacity.



Available in chrome finish.



colour  
included  
in the price

No additional payment for a color.