

Daikin Altherma low temperature split Technical Data

EBVH-D6V /
EBVH-D9W /
EBVX-D6V /
EBVX-D9W /
EBVZ-D6V /
EBVZ-D9W

EBVH11S18DJ6V
EBVH11S23DJ6V
EBVH16S18DJ6V
EBVH16S23DJ6V
EBVH11S18DJ9W
EBVH11S23DJ9W
EBVH16S18DJ9W
EBVH16S23DJ9W
EBVX11S18DJ6V
EBVX11S23DJ6V
EBVX16S18DJ6V
EBVX16S23DJ6V
EBVX11S18DJ9W
EBVX11S23DJ9W
EBVX16S18DJ9W
EBVX16S23DJ9W
EBVZ16S18DJ6V
EBVZ16S23DJ6V
EBVZ16S18DJ9W
EBVZ16S23DJ9W



TABLE OF CONTENTS

EBVH-D6V / EBVH-D9W / EBVX-D6V / EBVX-D9W / EBVZ-D6V / EBVZ-D9W

1	Features	4
	EBVH-D6V / EBVH-D9W / EBVX-D6V /	4
	EBVX-D9W / EBVZ-D6V / EBVZ-D9W	5
2	Specifications	6
3	Electrical data	20
4	Combination table	22
5	Capacity tables	23
	Domestic Hot Water performance	23
6	Dimensional drawings	24
7	Centre of gravity	25
8	Piping diagrams	26
9	Wiring diagrams	27
	Notes & Legend	27
	Control Circuit	28
	Power Supply, Back-up Heater	33
10	External connection diagrams	34
11	Installation	36
	Installation Method	36
12	Operation range	37
13	Hydraulic performance	38
	Static Pressure Drop Unit	38

1 Features

1 - 1 EBVZ-D6V, EBVZ-D9W

- > Small installation footprint, similar to other household appliances
- > A combined stainless steel domestic hot water tank of 180 or 230L and heat pump for easy installation
- > PCB board and hydraulic components are located in the front for easy access
- > W-LAN module and cartridge compatible
- > Bi-zone allows temperature monitoring for 2 zones. Connect underfloor heating to radiators to optimise efficiency



Daikin Residential Controller (optional)



Voice control

1 Features

1 - 2 EBVH-D6V / EBVH-D9W / EBVX-D6V / EBVX-D9W

- > Small installation footprint, similar to other household appliances
- > A combined stainless steel domestic hot water tank of 180 or 230L and heat pump for easy installation
- > PCB board and hydraulic components are located in the front for easy access
- > W-LAN module and cartridge compatible
- > Integrated back-up heater choice of 3, 6, 9 kW as well as back-up heater less models are available

1



Daikin Residential Controller (optional)



Voice control

2 Specifications

1 - 2 EBVH-D6V / EBVH-D9W / EBVX-D6V / EBVX-D9W

2

Technical specifications				EBVH11S18D6V	EBVH11S23D6V	EBVH16S18D6V	EBVH16S23D6V	
Heater capacity	Step 1		kW	2				
	Step 2		kW	2 or 4				
Efficiency	Domestic hot water	Net calorific value	%	116	109	116	109	
Casing	Colour	White + Black						
	Material	Precoated sheet metal						
Dimensions	Unit	Height	mm	1,655	1,855	1,655	1,855	
		Width	mm	595				
		Depth	mm	634				
	Packed unit	Height	mm	1,820	2,020	1,820	2,020	
		Width	mm	720				
		Depth	mm	740				
Weight	Unit		kg	124	133	124	133	
	Packed unit		kg	143	151	143	151	
Packing	Material	Wood / Carton / Metal / PE wrapping foil						
	Weight		kg	19				
PED	Category	Category II						
	Most critical part	Name		Plate heat exchanger				
		Ps*V	Bar*l	75				
Refrigerant side heat exchanger	Type	Plate heat exchanger						
	Quantity	1						
	Plates	Quantity	90					
Pump	Nr of speeds	PWM						
	Power input		W	75		140		
Water side Heat exchanger	Type	Plate heat exchanger						
	Model	ACH43-90AH-F						
	Quantity	1						
	Plates	Quantity	90					
	Water volume		l	2.16				
	Water flow rate	Min.	l/min	22.0 (1)				
Expansion vessel	Volume		l	10				
	Max. water pressure		bar	3				
	Pre pressure		bar	1				
Water filter	Diameter perforations		mm	0.8				
	Material	Stainless steel / Plastic						
Tank	Name			Stainless steel domestic hot water tank 180 l	Stainless steel domestic hot water tank 230 L	Stainless steel domestic hot water tank 180 l	Stainless steel domestic hot water tank 230 L	
	Water volume		l	180	230	180	230	
Tank	Material	Stainless steel (EN 1.4521)						
	Maximum water temperature	70.0						
	Maximum water pressure	10						
	Insulation	Material	Polyurethane foam					
		Heat loss		kWh/24h	1.2 (2)	1.4 (2)	1.2 (2)	1.4 (2)
	Corrosion protection	Pickling						
Energy efficiency class	B							
General	Supplier/ Manufacturer details	Name or trademark	Daikin Europe N.V.					
		Name and address	Daikin Europe N.V. - Zandvoordestraat 300, 8400 Oostende, Belgium					
3-way valve	Coefficient of flow (kV)	Space heating	m ³ /h	8				
		Domestic hot water tank	m ³ /h	10				
Water circuit	Piping connections diameter		inch	G 1" (female)				
	Piping material	Cu						
	Internal piping diameter		inch	1"				
	Piping		inch	1"				
	Safety valve		bar	3				
	Manometer	Digital						
	Drain valve / fill valve	Yes						
	Shut off valve	Yes						
	Air purge valve	Yes						
	Total water volume		l	5.1 (3)				
	Minimum water volume in the system for cooling		l	20				
	Minimum water volume in the system for heating		l	20				
	Water circuit - Domestic hot water side	Piping material	Cu					
Piping connections		Cold water in / Hot water out	inch	G 3/4" FEMALE				
		Recirculation connection	inch	G 3/4" FEMALE				

2 Specifications

1 - 2 EBVX-D9W, EBVX-D6V, EBVH-D9W, EBVH-D6V

Technical specifications					EBVH11S18D6V	EBVH11S23D6V	EBVH16S18D6V	EBVH16S23D6V
Refrigerant circuit	Gas side diameter	mm			15.9			
	Liquid side diameter	mm			9.50			
Sound power level	Nom.	dB(A)			44.0 (4)			
Sound pressure level	Nom.	dB(A)			30.0 (4)			
Operation range	Heating	Ambient	Min.	°C	-25 (5)			
			Max.	°C	35 (5)			
	Water side	Min.	°C		15 (5)			
			Max.	°C	60 (5)			
	Cooling	Ambient	Min.	°CDB	10 (5)			
			Max.	°CDB	43 (5)			
Water side	Min.	°C		5 (5)				
Operation range	Cooling	Water side	Max.	°C	22 (5)			
			Domestic hot water side	Min.	°C	25 (5)		
		Max.	°C		55 (5)			
Safety devices	Item	01			Thermal cut out			
Pump	Type				Grundfos UPM3LK 15-75 130 PWM		Grundfos UPML GEO 25-105 130 PWM	
Tank	Storage volume	V	I		181	220	181	220
	Standing heat loss	S	W		50	58	50	58

Electrical specifications					EBVH11S18D6V	EBVH11S23D6V	EBVH16S18D6V	EBVH16S23D6V
Power supply	Name				See note 7			
	Voltage range	Min.	%		-10			
Max.		%			10			
IP class	IP				X0			
Electric heater	Power supply	Name			6V3			
		Phase			1~ / 3~			
		Frequency	Hz		50			
	Current	Maximum running current	V		230			
			A		26.0			
			Zmax List	Ω	0.22			
Minimum Ssc value			Equipment complying with EN/IEC 61000-3-12					
Recommended fuses	A			20 (6)				
Wiring connections	Communication cable	Quantity			3			
		Remark			2.5 mm ²			
	Electric meter	Quantity			2			
		Remark			Minimum 0.75 mm ² (5VDC pulse detection)			
	Preferential kWh rate power supply	Quantity			Power: 2			
		Remark			Power 6.3A (Select diameter and type according to national and local regulations)			
	Domestic hot water pump	Quantity			2			
		Remark			Minimum 0.75 mm ² (2A inrush, 1A continuous)			
	For power supply back-up heater	Quantity			Prewired			
		Remark						
	For connection with R6T	Quantity			2			
		Remark			Minimum 0.75 mm ²			
	For connection with A3P	Quantity			Depends on thermostat type, cf. installation manual			
		Remark			Voltage: 230V / Max. current: 100mA / Min. 0.75mm ²			
For connection with M2S	Quantity			2				
	Remark			Voltage: 230V / Max. current: 100mA / Min. 0.75mm ²				
For connection with optional	Quantity			4				
	Remark			100 mA, minimum 0.75 mm ²				

(1) Operation area is extended to lower flow rates depending on operation mode - refer to ESP curve. |

(2) Based on a dT of 45 K |

(3) Including piping + PHE + back-up heater; excluding expansion vessel |

(4) Measured with a pressure drop of 10 kPa in the heating system at an operating condition of leaving water 47-55°C in a room with an ambient of 20°C. DB/WB 7°C/6°. |

(5) For more details, see operation range drawing |

(6) 4 pole 20 A curve 400V tripping class C (refer to wiring diagram) |

(7) Above mentioned power supply of the hydrobox is for the backup heater only. The switch box and the pump of the hydrobox are supplied via the outdoor unit. The optional domestic hot water tank has a separate power supply.

2 Specifications

1 - 2 EBVH-D6V / EBVH-D9W / EBVX-D6V / EBVX-D9W

2

Technical specifications				EBVH11S18D9W	EBVH11S23D9W	EBVH16S18D9W	EBVH16S23D9W	
Heater capacity	Step 1		kW	3				
	Step 2		kW	max. 6 kW				
Efficiency	Domestic hot water	Net calorific value	%	116	109	116	109	
	Casing			White + Black				
Material			Precoated sheet metal					
Dimensions	Unit	Height	mm	1,655	1,855	1,655	1,855	
		Width	mm	595				
		Depth	mm	634				
	Packed unit	Height	mm	1,820	2,020	1,820	2,020	
		Width	mm	720				
		Depth	mm	740				
Weight	Unit		kg	124	133	124	133	
	Packed unit		kg	143	151	143	151	
Packing	Material			Wood / Carton / Metal / PE wrapping foil				
	Weight			kg				
PED	Category			19				
	Most critical part	Name	Bar* ^l	Category II				
		Plate heat exchanger			75			
Refrigerant side heat exchanger	Type			Plate heat exchanger				
	Quantity			1				
	Plates	Quantity		90				
Pump	Nr of speeds			PWM				
	Power input			W	75		140	
Water side Heat exchanger	Type			Plate heat exchanger				
	Model			ACH43-90AH-F				
	Quantity			1				
	Plates	Quantity		90				
	Water volume			l				
	Water flow rate	Min.	l/min	22.0 (1)				
Expansion vessel	Volume			l				
	Max. water pressure			bar				
	Pre pressure			bar				
Water filter	Diameter perforations			mm				
	Material			Stainless steel / Plastic				
Tank	Name			Stainless steel domestic hot water tank 180 l	Stainless steel domestic hot water tank 230 L	Stainless steel domestic hot water tank 180 l	Stainless steel domestic hot water tank 230 L	
	Water volume			l	180	230	180	230
Tank	Material			Stainless steel (EN 1.4521)				
	Maximum water temperature			°C				
	Maximum water pressure			bar				
	Insulation	Material			Polyurethane foam			
		Heat loss	kWh/24h		1.2 (2)	1.4 (2)	1.2 (2)	1.4 (2)
	Corrosion protection			Pickling				
Energy efficiency class			B					
General	Supplier/Manufacturer	Name or trademark		Daikin Europe N.V.				
	Name and address			Daikin Europe N.V. - Zandvoordestraat 300, 8400 Oostende, Belgium				
3-way valve	Coefficient of flow (kV)	Space heating	m ³ /h	8				
		Domestic hot water tank	m ³ /h	10				
Water circuit	Piping connections diameter			inch				
	Piping material			Cu				
	Internal piping diameter			inch				
	Piping			inch				
	Safety valve			bar				
	Manometer			Digital				
	Drain valve / fill valve			Yes				
	Shut off valve			Yes				
	Air purge valve			Yes				
	Total water volume			l				
	Minimum water volume in the system for cooling			l				
	Minimum water volume in the system for heating			l				
	Water circuit - Domestic hot water side	Piping material			Cu			
		Piping connections	Cold water in / Hot water out	inch	G 3/4" FEMALE			
Recirculation connection			inch	G 3/4" FEMALE				

2 Specifications

1 - 2 EBVH-D6V / EBVH-D9W / EBVX-D6V / EBVX-D9W

Technical specifications					EBVH11S18D9W	EBVH11S23D9W	EBVH16S18D9W	EBVH16S23D9W
Refrigerant circuit	Gas side diameter	mm			15.9			
	Liquid side diameter	mm			9.50			
Sound power level	Nom.	dBA			44.0 (4)			
Sound pressure level	Nom.	dBA			30.0 (4)			
Operation range	Heating	Ambient	Min.	°C	-25 (5)			
			Max.	°C	35 (5)			
	Water side	Min.	°C	15 (5)				
			Max.	°C	60 (5)			
	Cooling	Ambient	Min.	°CDB	10 (5)			
			Max.	°CDB	43 (5)			
Water side	Min.	°C	5 (5)					
Operation range	Cooling	Water side	Max.	°C	22 (5)			
			Domestic hot water side	Min.	°C	25 (5)		
		Max.		°C	55 (5)			
Safety devices	Item	01			Thermal cut out			
Pump	Type				Grundfos UPM3LK 15-75 130 PWM		Grundfos UPML GEO 25-105 130 PWM	
Tank	Storage volume	V	I		181	220	181	220
	Standing heat loss	S	W		50	58	50	58

Electrical specifications					EBVH11S18D9W	EBVH11S23D9W	EBVH16S18D9W	EBVH16S23D9W	
Power supply	Name				See note 7				
	Voltage range	Min.	%		-10				
Max.		%		10					
IP class	IP				X0				
Electric heater	Power supply	Name			9W				
		Phase			3~				
		Frequency	Hz			50			
		Voltage	V			400			
	Current	Maximum running current	A			13.0			
Recommended fuses			A			20 (6)			
Wiring connections	Communication cable	Quantity			3				
		Remark			2.5 mm ²				
	Electric meter	Quantity			2				
		Remark			Minimum 0.75 mm ² (5VDC pulse detection)				
	Preferential kWh rate power supply	Quantity			Power: 2				
		Remark			Power 6.3A (Select diameter and type according to national and local regulations)				
	Domestic hot water pump	Quantity			2				
		Remark			Minimum 0.75 mm ² (2A inrush, 1A continuous)				
	For power supply back-up heater	Quantity			Prewired				
		Remark							
For connection with R6T	Quantity			2					
	Remark			Minimum 0.75 mm ²					
For connection with A3P	Quantity			Depends on thermostat type, cf. installation manual					
	Remark			Voltage: 230V / Max. current: 100mA / Min. 0.75mm ²					
For connection with M2S	Quantity			2					
	Remark			Voltage: 230V / Max. current: 100mA / Min. 0.75mm ²					
For connection with optional	Quantity			4					
	Remark			100 mA, minimum 0.75 mm ²					

(1) Operation area is extended to lower flow rates depending on operation mode - refer to ESP curve. |

(2) Based on a dT of 45 K |

(3) Including piping + PHE + back-up heater; excluding expansion vessel |

(4) Measured with a pressure drop of 10 kPa in the heating system at an operating condition of leaving water 47-55°C in a room with an ambient of 20°C. DB/WB 7°C/6° |

(5) For more details, see operation range drawing |

(6) 4 pole 20 A curve 400V tripping class C (refer to wiring diagram) |

(7) Above mentioned power supply of the hydrobox is for the backup heater only. The switch box and the pump of the hydrobox are supplied via the outdoor unit. The optional domestic hot water tank has a separate power supply.

2 Specifications

1 - 2 EBVH-D6V / EBVH-D9W / EBVX-D6V / EBVX-D9W

2

Technical specifications				EBVX11S18D6V	EBVX11S23D6V	EBVX16S18D6V	EBVX16S23D6V	
Heater capacity	Step 1	kW					2	
	Step 2	kW					2 or 4	
Efficiency	Domestic hot water	Net calorific value	%	116	109	116	109	
	Casing			White + Black				
Material			Precoated sheet metal					
Dimensions	Unit	Height	mm	1,655	1,855	1,655	1,855	
		Width	mm	595				
		Depth	mm	634				
	Packed unit	Height	mm	1,820	2,020	1,820	2,020	
		Width	mm	720				
		Depth	mm	740				
Weight	Unit	kg	124	133	124	133		
	Packed unit	kg	143	151	143	151		
Packing	Material	Wood / Carton / Metal / PE wrapping foil						
	Weight	kg	19					
PED	Category		Category II					
	Most critical part	Name	Plate heat exchanger					
	Ps*V	Bar*l	75					
Refrigerant side heat exchanger	Type	Plate heat exchanger						
	Quantity	1						
	Plates	Quantity	90					
Pump	Nr of speeds	PWM						
	Power input	W	75		140			
Water side Heat exchanger	Type	Plate heat exchanger						
	Model	ACH43-90AH-F						
	Quantity	1						
	Plates	Quantity	90					
	Water volume	l	2.16					
	Water flow rate	Min.	l/min	22.0 (1)				
Expansion vessel	Volume	l	10					
	Max. water pressure	bar	3					
	Pre pressure	bar	1					
Water filter	Diameter perforations	mm	0.8					
	Material	Stainless steel / Plastic						
Tank	Name		Stainless steel domestic hot water tank 180 l	Stainless steel domestic hot water tank 230 L	Stainless steel domestic hot water tank 180 l	Stainless steel domestic hot water tank 230 L		
	Water volume	l	180	230	180	230		
Tank	Material	Stainless steel (EN 1.4521)						
	Maximum water temperature	°C	70.0					
	Maximum water pressure	bar	10					
	Insulation	Material	Polyurethane foam					
		Heat loss	kWh/24h	1.2 (2)	1.4 (2)	1.2 (2)	1.4 (2)	
	Corrosion protection	Pickling						
Energy efficiency class	B							
General	Supplier/ Manufacturer details	Name or trademark	Daikin Europe N.V.					
		Name and address	Daikin Europe N.V. - Zandvoordestraat 300, 8400 Oostende, Belgium					
3-way valve	Coefficient of flow (kV)	Space heating	m ³ /h	8				
		Domestic hot water tank	m ³ /h	10				
Water circuit	Piping connections diameter		inch	G 1" (female)				
	Piping material			Cu				
	Internal piping diameter		inch	1"				
	Piping		inch	1"				
	Safety valve		bar	3				
	Manometer			Digital				
	Drain valve / fill valve			Yes				
	Shut off valve			Yes				
	Air purge valve			Yes				
	Total water volume		l	5.1 (3)				
	Minimum water volume in the system for cooling		l	20				
	Minimum water volume in the system for heating		l	20				
	Water circuit - Domestic hot water side	Piping material			Cu			
		Piping connections	Cold water in / Hot water out	inch	G 3/4" FEMALE			
Recirculation connection			inch	G 3/4" FEMALE				

2 Specifications

1 - 2 EBVH-D6V / EBVH-D9W / EBVX-D6V / EBVX-D9W

Technical specifications					EBVX11S18D6V	EBVX11S23D6V	EBVX16S18D6V	EBVX16S23D6V
Refrigerant circuit	Gas side diameter	mm			15.9			
	Liquid side diameter	mm			9.50			
Sound power level	Nom.	dB(A)			44.0 (4)			
Sound pressure level	Nom.	dB(A)			30.0 (4)			
Operation range	Heating	Ambient	Min.	°C	-25 (5)			
			Max.	°C	35 (5)			
	Water side	Min.	°C		15 (5)			
			Max.	°C	60 (5)			
	Cooling	Ambient	Min.	°CDB	10 (5)			
			Max.	°CDB	43 (5)			
Water side	Min.	°C		5 (5)				
Operation range	Cooling	Water side	Max.	°C	22 (5)			
			Domestic hot water side	Min.	°C	25 (5)		
			Max.	°C	55 (5)			
Safety devices	Item	01			Thermal cut out			
Pump	Type				Grundfos UPM3LK 15-75 130 PWM		Grundfos UPML GEO 25-105 130 PWM	
Tank	Storage volume	V	I		181	220	181	220
	Standing heat loss	S	W		50	58	50	58

Electrical specifications					EBVX11S18D6V	EBVX11S23D6V	EBVX16S18D6V	EBVX16S23D6V
Power supply	Name				See note 7			
	Voltage range	Min.	%		-10			
Max.		%			10			
IP class	IP				X0			
Electric heater	Power supply	Name			6V3			
		Phase			1~ / 3~			
		Frequency	Hz		50			
	Current	Voltage	V		230			
		Maximum running current	A		26.0			
		Zmax List	Ω		0.22			
Minimum Ssc value				Equipment complying with EN/IEC 61000-3-12				
Recommended fuses		A		20 (6)				
Wiring connections	Communication cable	Quantity			3			
		Remark			2.5 mm ²			
	Electric meter	Quantity			2			
		Remark			Minimum 0.75 mm ² (5VDC pulse detection)			
	Preferential kWh rate power supply	Quantity			Power: 2			
		Remark			Power 6.3A (Select diameter and type according to national and local regulations)			
	Domestic hot water pump	Quantity			2			
		Remark			Minimum 0.75 mm ² (2A inrush, 1A continuous)			
	For power supply back-up heater	Quantity			Prewired			
		Remark						
	For connection with R6T	Quantity			2			
		Remark			Minimum 0.75 mm ²			
	For connection with A3P	Quantity			Depends on thermostat type, cf. installation manual			
Remark				Voltage: 230V / Max. current: 100mA / Min. 0.75mm ²				
For connection with M2S	Quantity			2				
	Remark			Voltage: 230V / Max. current: 100mA / Min. 0.75mm ²				
For connection with optional	Quantity			4				
	Remark			100 mA, minimum 0.75 mm ²				

(1) Operation area is extended to lower flow rates depending on operation mode - refer to ESP curve. |

(2) Based on a dT of 45 K |

(3) Including piping + PHE + back-up heater; excluding expansion vessel |

(4) Measured with a pressure drop of 10 kPa in the heating system at an operating condition of leaving water 47-55°C in a room with an ambient of 20°C. DB/WB 7°C/6°. |

(5) For more details, see operation range drawing |

(6) 4 pole 20 A curve 400V tripping class C (refer to wiring diagram) |

(7) Above mentioned power supply of the hydrobox is for the backup heater only. The switch box and the pump of the hydrobox are supplied via the outdoor unit. The optional domestic hot water tank has a separate power supply.

2 Specifications

1 - 2 EBVH-D6V / EBVH-D9W / EBVX-D6V / EBVX-D9W

2

Technical specifications				EBVX11S18D9W	EBVX11S23D9W	EBVX16S18D9W	EBVX16S23D9W	
Heater capacity	Step 1		kW	3				
	Step 2		kW	max. 6 kW				
Efficiency	Domestic hot water	Net calorific value	%	116	109	116	109	
	Casing			White + Black				
Material			Precoated sheet metal					
Dimensions	Unit	Height	mm	1,655	1,855	1,655	1,855	
		Width	mm	595				
		Depth	mm	634				
	Packed unit	Height	mm	1,820	2,020	1,820	2,020	
		Width	mm	720				
		Depth	mm	740				
Weight	Unit		kg	124	133	124	133	
	Packed unit		kg	143	151	143	151	
Packing	Material			Wood / Carton / Metal / PE wrapping foil				
	Weight			kg				
PED	Category			19				
	Most critical part	Name	Bar* ^l	Category II				
		Plate heat exchanger			75			
Refrigerant side heat exchanger	Type			Plate heat exchanger				
	Quantity			1				
	Plates	Quantity		90				
Pump	Nr of speeds			PWM				
	Power input			W	75		140	
Water side Heat exchanger	Type			Plate heat exchanger				
	Model			ACH43-90AH-F				
	Quantity			1				
	Plates	Quantity		90				
	Water volume			l				
	Water flow rate	Min.	l/min	22.0 (1)				
Expansion vessel	Volume			l				
	Max. water pressure			bar				
	Pre pressure			bar				
Water filter	Diameter perforations			mm				
	Material			Stainless steel / Plastic				
Tank	Name			Stainless steel domestic hot water tank 180 l	Stainless steel domestic hot water tank 230 L	Stainless steel domestic hot water tank 180 l	Stainless steel domestic hot water tank 230 L	
	Water volume			l	180	230	180	230
Tank	Material			Stainless steel (EN 1.4521)				
	Maximum water temperature			°C				
	Maximum water pressure			bar				
	Insulation	Material			Polyurethane foam			
		Heat loss	kWh/24h		1.2 (2)	1.4 (2)	1.2 (2)	1.4 (2)
	Corrosion protection			Pickling				
Energy efficiency class			B					
General	Supplier/Manufacturer	Name or trademark and address		Daikin Europe N.V.				
	factory details			Daikin Europe N.V. - Zandvoordestraat 300, 8400 Oostende, Belgium				
3-way valve	Coefficient of flow (kV)	Space heating	m ³ /h	8				
		Domestic hot water tank	m ³ /h	10				
Water circuit	Piping connections diameter			inch				
	Piping material			G 1" (female)				
	Internal piping diameter			inch				
	Piping			inch				
	Safety valve			bar				
	Manometer			Digital				
	Drain valve / fill valve			Yes				
	Shut off valve			Yes				
	Air purge valve			Yes				
	Total water volume			l				
	Minimum water volume in the system for cooling			l				
	Minimum water volume in the system for heating			l				
	Water circuit - Domestic hot water side	Piping material			Cu			
		Piping connections	Cold water in / Hot water out	inch	G 3/4" FEMALE			
Recirculation connection			inch	G 3/4" FEMALE				

2 Specifications

1 - 2 EBVH-D6V / EBVH-D9W / EBVX-D6V / EBVX-D9W

Technical specifications					EBVX11S18D9W	EBVX11S23D9W	EBVX16S18D9W	EBVX16S23D9W
Refrigerant circuit	Gas side diameter	mm			15.9			
	Liquid side diameter	mm			9.50			
Sound power level	Nom.	dBA			44.0 (4)			
Sound pressure level	Nom.	dBA			30.0 (4)			
Operation range	Heating	Ambient	Min.	°C	-25 (5)			
			Max.	°C	35 (5)			
	Water side	Min.	°C	15 (5)				
			Max.	°C	60 (5)			
	Cooling	Ambient	Min.	°CDB	10 (5)			
			Max.	°CDB	43 (5)			
Water side	Min.	°C	5 (5)					
Operation range	Cooling	Water side	Max.	°C	22 (5)			
			Domestic hot water side	Min.	°C	25 (5)		
			Max.	°C	55 (5)			
Safety devices	Item	01			Thermal cut out			
Pump	Type				Grundfos UPM3LK 15-75 130 PWM		Grundfos UPML GEO 25-105 130 PWM	
Tank	Storage volume	V	I		181	220	181	220
	Standing heat loss	S	W		50	58	50	58

Electrical specifications					EBVX11S18D9W	EBVX11S23D9W	EBVX16S18D9W	EBVX16S23D9W
Power supply	Name				See note 7			
	Voltage range	Min.	%		-10			
Max.		%		10				
IP class	IP				X0			
Electric heater	Power supply	Name			9W			
		Phase			3~			
		Frequency	Hz		50			
		Voltage	V		400			
	Current	Maximum running current	A		13.0			
	Recommended fuses	A		20 (6)				
Wiring connections	Communication cable	Quantity			3			
		Remark			2.5 mm ²			
	Electric meter	Quantity			2			
		Remark			Minimum 0.75 mm ² (5VDC pulse detection)			
	Preferential kWh rate power supply	Quantity			Power: 2			
		Remark			Power 6.3A (Select diameter and type according to national and local regulations)			
	Domestic hot water pump	Quantity			2			
		Remark			Minimum 0.75 mm ² (2A inrush, 1A continuous)			
	For power supply back-up heater	Quantity			Prewired			
		Remark						
	For connection with R6T	Quantity			2			
		Remark			Minimum 0.75 mm ²			
For connection with A3P	Quantity			Depends on thermostat type, cf. installation manual				
	Remark			Voltage: 230V / Max. current: 100mA / Min. 0.75mm ²				
For connection with M2S	Quantity			2				
	Remark			Voltage: 230V / Max. current: 100mA / Min. 0.75mm ²				
For connection with optional	Quantity			4				
	Remark			100 mA, minimum 0.75 mm ²				

(1) Operation area is extended to lower flow rates depending on operation mode - refer to ESP curve. |

(2) Based on a dT of 45 K |

(3) Including piping + PHE + back-up heater; excluding expansion vessel |

(4) Measured with a pressure drop of 10 kPa in the heating system at an operating condition of leaving water 47-55°C in a room with an ambient of 20°C. DB/WB 7°C/6° |

(5) For more details, see operation range drawing |

(6) 4 pole 20 A curve 400V tripping class C (refer to wiring diagram) |

(7) Above mentioned power supply of the hydrobox is for the backup heater only. The switch box and the pump of the hydrobox are supplied via the outdoor unit. The optional domestic hot water tank has a separate power supply.

2 Specifications

1 - 2 EBVZ-D6V / EBVZ-D9W

2

Technical specifications				EBVZ16S18D6V		EBVZ16S23D6V	
Heater capacity	Step 1		kW	2			
	Step 2		kW	2 or 4			
Efficiency	Domestic hot water	Net calorific value	%	116		109	
	Casing			White + Black			
Material			Precoated sheet metal				
Dimensions	Unit	Height	mm	1,655		1,855	
		Width	mm	595			
		Depth	mm	634			
	Packed unit	Height	mm	1,820		2,020	
		Width	mm	720			
		Depth	mm	740			
Weight	Unit		kg	137		145	
	Packed unit		kg	156		164	
Packing	Material			Wood / Carton / Metal / PE wrapping foil			
	Weight			kg			
PED	Category			19			
	Most critical part			Category II			
	Name	Ps*V	Bar*l	Plate heat exchanger			
				75			
Refrigerant side heat exchanger	Type			Plate heat exchanger			
	Quantity			1			
	Plates	Quantity		90			
Pump Additional Zone	Nr of speeds			PWM			
	Power input			W			
	Type			Grundfos UPM3LK 15-75 130 PWM			
Pump Main Zone	Nr of speeds			PWM			
	Power input			W			
	Type			Grundfos UPM3LK 15-75 130 PWM			
Water side Heat exchanger	Type			Plate heat exchanger			
	Model			ACH43-90AH-F			
	Quantity			1			
	Plates	Quantity		90			
	Water volume			l			
	Water flow rate	Min.	l/min	22.0 (1)			
	Expansion vessel			Volume			
			l				
			Max. water pressure				
			bar				
			Pre pressure				
			bar				
Water Filter Additional Zone	Diameter perforations			mm			
	Material			Plastic / Stainless steel			
Water filter Main Zone	Diameter perforations			mm			
	Material			Copper - brass - stainless steel			
Tank	Name			Stainless steel domestic hot water tank 180 l		Stainless steel domestic hot water tank 230 L	
	Water volume			l		180	
	Material			Stainless steel (EN 1.4521)			
	Maximum water temperature			°C			
				70.0			
	Maximum water pressure			bar			
				10			
	Insulation	Material	Polyurethane foam				
	Heat loss	kWh/24h	1.2 (2)		1.4 (2)		
	Corrosion protection			Pickling			
Energy efficiency class			B				
General	Supplier/ Manufacturer details	Name or trademark		Daikin Europe N.V.			
	Name and address		Daikin Europe N.V. - Zandvoordestraat 300, 8400 Oostende, Belgium				
3-way valve	Coefficient of flow (kV)	Space heating	m ³ /h	8			
		Domestic hot water tank	m ³ /h	10			
3-way valve mixing	Coefficient of flow (kV)	Bypass	m ³ /h	13			
		Main zone only	m ³ /h	8			
Water circuit	Total water volume			l			
	Minimum water volume in the system for cooling			l			
	Minimum water volume in the system for heating			l			
Water circuit - space heating side (additional zone)	Air purge valve			Yes			
	Drain valve / fill valve			No			
	Manometer			Yes			
	Piping connections diameter			inch			
				G 1" (FEMALE)			
	Safety valve			bar			
Shut off valve			Yes				

2 Specifications

1 - 2 EBVZ-D6V / EBVZ-D9W

Technical specifications				EBVZ16S18D6V	EBVZ16S23D6V
Water circuit - space heating side (main zone)	Air purge valve			No	
	Drain valve / fill valve			Yes	
	Manometer			No	
	Piping connections diameter	inch		G 1 (FEMALE)	
	Safety valve	bar		3	
Water circuit - Domestic hot water side	Shut off valve			Yes	
	Piping material			Cu	
	Piping connections	Cold water in / Hot water out inch		G 3/4" FEMALE	
Refrigerant circuit	Recirculation connection		inch	G 3/4" FEMALE	
	Gas side diameter	mm		15.9	
Sound power level	Liquid side diameter		mm	9.50	
	Nom.	dBa		44.0 (4)	
Sound pressure level	Nom.		dBa	30.0 (4)	
	Operation range	Heating	Ambient	Min.	°C
Max.				°C	35 (5)
Water side		Min.	°C	15 (5)	
			Max.	°C	60 (5)
Cooling		Ambient	Min.	°CDB	10 (5)
			Max.	°CDB	43 (5)
Water side		Min.	°C	5 (5)	
			Max.	°C	22 (5)
Domestic hot water side		Min.	°C	25 (5)	
			Max.	°C	55 (5)
Safety devices	Item	01		Thermal cut out	
	Tank	Storage volume	V	l	181
Standing heat loss		S	W	50	58

Electrical specifications				EBVZ16S18D6V	EBVZ16S23D6V	
Power supply	Name			See note 7		
	Voltage range	Min.	%	-10		
Max.		%		10		
IP class	IP			X0		
Electric heater	Power supply	Name		6V3		
		Phase		1~ / 3~		
		Frequency	Hz	50		
	Current	Voltage		V	230	
		Maximum running current		A	26.0	
		Zmax	List	Ω	0.22	
		Minimum Ssc value			Equipment complying with EN/IEC 61000-3-12	
Recommended fuses		A		20 (6)		

2 Specifications

1 - 2 EBVZ-D6V / EBVZ-D9W

2

Electrical specifications			EBVZ16S18D6V	EBVZ16S23D6V
Wiring connections	Communication cable	Quantity	3	
		Remark	2.5 mm ²	
	Electric meter	Quantity	2	
		Remark	Minimum 0.75 mm ² (5VDC pulse detection)	
	Preferential kWh rate power supply	Quantity	Power: 2	
		Remark	Power 6.3A (Select diameter and type according to national and local regulations)	
	Domestic hot water pump	Quantity	2	
		Remark	Minimum 0.75 mm ² (2A inrush, 1A continuous)	
	For power supply back-up heater	Quantity	Prewired	
		Remark		
	For connection with R6T	Quantity	2	
		Remark	Minimum 0.75 mm ²	
	For connection with A3P	Quantity	Depends on thermostat type, cf. installation manual	
		Remark	Voltage: 230V / Max. current: 100mA / Min. 0.75mm ²	
For connection with M2S	Quantity	2		
	Remark	Voltage: 230V / Max. current: 100mA / Min. 0.75mm ²		
For connection with optional	Quantity	4		
	Remark	100 mA, minimum 0.75 mm ²		

(1)Operation area is extended to lower flow rates depending on operation mode - refer to ESP curve. |

(2)Based on a dT of 45 K |

(3)Including piping + PHE + back-up heater; excluding expansion vessel |

(4)Measured with a pressure drop of 10 kPa in the heating system at an operating condition of leaving water 47-55°C in a room with an ambient of 20°C. DB/WB 7°C/6°. |

(5)For more details, see operation range drawing |

(6)4 pole 20 A curve 400V tripping class C (refer to wiring diagram) |

(7)Above mentioned power supply of the hydrobox is for the backup heater only. The switch box and the pump of the hydrobox are supplied via the outdoor unit. The optional domestic hot water tank has a separate power supply.

Technical specifications				EBVZ16S18D9W	EBVZ16S23D9W
Heater capacity	Step 1	kW	3		
	Step 2	kW	max. 6 kW		
Efficiency	Domestic hot water	Net calorific value	%	116	109
Casing	Colour	White + Black			
	Material	Precoated sheet metal			
Dimensions	Unit	Height	mm	1,655	1,855
		Width	mm	595	
		Depth	mm	634	
	Packed unit	Height	mm	1,820	2,020
		Width	mm	720	
		Depth	mm	740	
Weight	Unit	kg	137	145	
	Packed unit	kg	156	164	
Packing	Material	Wood / Carton / Metal / PE wrapping foil			
	Weight	kg	19		
PED	Category	Category II			
	Most critical part	Name	Plate heat exchanger		
		Ps*V	Bar*l	75	
Refrigerant side heat exchanger	Type	Plate heat exchanger			
	Quantity	1			
	Plates	Quantity	90		
Pump Additional Zone	Nr of speeds	PWM			
	Power input	W	75		
	Type	Grundfos UPM3LK 15-75 130 PWM			
Pump Main Zone	Nr of speeds	PWM			
	Power input	W	75		
	Type	Grundfos UPM3LK 15-75 130 PWM			
Water side Heat exchanger	Type	Plate heat exchanger			
	Model	ACH43-90AH-F			
	Quantity	1			
	Plates	Quantity	90		
	Water volume	l	2.16		
	Water flow rate	Min.	l/min	22.0 (1)	

2 Specifications

1 - 2 EBVZ-D6V / EBVZ-D9W

Technical specifications				EBVZ16S18D9W	EBVZ16S23D9W
Expansion vessel	Volume	l		10	
	Max. water pressure	bar		3	
	Pre pressure	bar		1	
Water Filter Additional Zone	Diameter perforations	mm		0.8	
	Material			Plastic / Stainless steel	
Water filter Main Zone	Diameter perforations	mm		1.0	
	Material			Copper - brass - stainless steel	
Tank	Name			Stainless steel domestic hot water tank 180 l	Stainless steel domestic hot water tank 230 L
	Water volume	l		180	230
	Material			Stainless steel (EN 1.4521)	
	Maximum water temperature	°C		70.0	
	Maximum water pressure	bar		10	
	Insulation Material			Polyurethane foam	
	Heat loss	kWh/24h		1.2 (2)	1.4 (2)
	Corrosion protection			Pickling	
	Energy efficiency class			B	
General	Supplier/ Name or trademark			Daikin Europe N.V.	
	Manufacturer Name and address			Daikin Europe N.V. - Zandvoordestraat 300, 8400 Oostende, Belgium	
3-way valve	Coefficient of flow (kV)	Space heating	m ³ /h	8	
		Domestic hot water tank	m ³ /h	10	
3-way valve mixing	Coefficient of flow (kV)	Bypass	m ³ /h	13	
		Main zone only	m ³ /h	8	
Water circuit	Total water volume	l		5.8 (3)	
	Minimum water volume in the system for cooling	l		20	
	Minimum water volume in the system for heating	l		20	
Water circuit - space heating side (additional zone)	Air purge valve			Yes	
	Drain valve / fill valve			No	
	Manometer			Yes	
	Piping connections diameter	inch		G 1" (FEMALE)	
	Safety valve	bar		3	
Water circuit - space heating side (main zone)	Shut off valve			Yes	
	Air purge valve			No	
	Drain valve / fill valve			Yes	
	Manometer			No	
	Piping connections diameter	inch		G 1 (FEMALE)	
Water circuit - Domestic hot water side	Safety valve	bar		3	
	Shut off valve			Yes	
	Piping material			Cu	
Refrigerant circuit	Piping Cold water in / Hot water out	inch		G 3/4" FEMALE	
	Recirculation connection	inch		G 3/4" FEMALE	
Sound power level	Gas side diameter	mm		15.9	
	Liquid side diameter	mm		9.50	
Sound pressure level	Nom.	dBA		44.0 (4)	
	Nom.	dBA		30.0 (4)	
Operation range	Heating	Ambient	Min.	°C	-25 (5)
			Max.	°C	35 (5)
	Water side	Min.	°C	15 (5)	
			Max.	°C	60 (5)
	Cooling	Ambient	Min.	°CDB	10 (5)
			Max.	°CDB	43 (5)
	Water side	Min.	°C	5 (5)	
			Max.	°C	22 (5)
	Domestic hot water side	Water	Min.	°C	25 (5)
			Max.	°C	55 (5)
Safety devices	Item	01		Thermal cut out	
	Tank Storage volume	V	l	181	220
	Standing heat loss	S	W	50	58

2 Specifications

1 - 2 EBVZ-D6V / EBVZ-D9W

2

Electrical specifications			EBVZ16S18D9W	EBVZ16S23D9W	
Power supply	Name		See note 7		
	Voltage range	Min.	%	-10	
		Max.	%		10
IP class	IP			X0	
Electric heater	Power supply	Name		9W	
		Phase		3~	
		Frequency	Hz		50
		Voltage	V		400
	Current	Maximum running current	A		13.0
	Recommended fuses		A		20 (6)
Wiring connections	Communication cable	Quantity		3	
		Remark		2.5 mm ²	
	Electric meter	Quantity			2
		Remark		Minimum 0.75 mm ² (5VDC pulse detection)	
	Preferential kWh rate power supply	Quantity			Power: 2
		Remark		Power 6.3A (Select diameter and type according to national and local regulations)	
	Domestic hot water pump	Quantity			2
		Remark		Minimum 0.75 mm ² (2A inrush, 1A continuous)	
	For power supply back-up heater	Quantity			Prewired
		Remark			
	For connection with R6T	Quantity			2
		Remark		Minimum 0.75 mm ²	
	For connection with A3P	Quantity			Depends on thermostat type, cf. installation manual
		Remark		Voltage: 230V / Max. current: 100mA / Min. 0.75mm ²	
For connection with M2S	Quantity			2	
	Remark		Voltage: 230V / Max. current: 100mA / Min. 0.75mm ²		
For connection with optional	Quantity			4	
	Remark		100 mA, minimum 0.75 mm ²		

(1) Operation area is extended to lower flow rates depending on operation mode - refer to ESP curve. |

(2) Based on a dT of 45 K |

(3) Including piping + PHE + back-up heater; excluding expansion vessel |

(4) Measured with a pressure drop of 10 kPa in the heating system at an operating condition of leaving water 47-55°C in a room with an ambient of 20°C. DB/WB 7°C/6°. |

(5) For more details, see operation range drawing |

(6) 4 pole 20 A curve 400V tripping class C (refer to wiring diagram) |

(7) Above mentioned power supply of the hydrobox is for the backup heater only. The switch box and the pump of the hydrobox are supplied via the outdoor unit. The optional domestic hot water tank has a separate power supply.

2 Specifications

1 - 2 EBVZ-D6V / EBVZ-D9W

3 Electrical data

3 - 1 Electrical Data

3

EBBH-D6V / EBBH-D9W
EBBX-D6V / EBBX-D9W
EBVH-D6V / EBVH-D9W / EBVH-UD6V
EBVX-D6V / EBVX-D9W
EBVZ-D6V / EBVZ-D9W

Electrical specifications of the backup heaters and booster heaters

Type	6V				9W							
	2 - 4	2 - 6	2-4 (in case of emergency: 2)	6	3 - 6	3 - 9	3 - 6 (in case of	9				
Capacity setting	[kW]				3							
Capacity stage -					1							
Capacity stage -1-	2	2	2	2	2	2	2	2				
Capacity stage -2-	4	6	4	6	6	9	6	9				
Backup heater	Minimum time delay between stages											
					Note 4-							
	Power supply	Phase	1~		3~		3~					
	(1)	Frequency	50		50		50					
		Voltage	230 +-10%		230 +-10%		400 +-10%					
		Nominal running current	A	17,4	26,1	17,4	26,1	15	8,7	13	8,7	13
Current	Zmax (backup heater)	(2)	Complex		0,22		-		-			
	Minimum Ssc value				(3)							
Booster heater (optional)* (KHW-models)	Capacity setting	kW				3						
	Capacity stage -					1						
	Minimum time delay between stages											
	Nominal running current		+EK*V3	A		13						
	Booster heater		+EK*Z2			75						
	Zmax	Booster heater	(2)	Complex		-		-				
Nominal running current	Backup heater +-	Booster heater	Backup heater +- EK*V3	30,4 (17,4+13)	39,1 (26,1+13)	30,4 (17,4+13)	39,1 (26,1+13)	28 (15 + 13)	21,7 (8,7+13)	26 (13+13)	21,7 (8,7+13)	26 (13+13)
			Backup heater +- EK*Z2					22,5 (15 + 7,5)	16,2 (8,7+7,5)	20,5 (13+7,5)	16,2 (8,7+7,5)	20,5 (13+7,5)
			Booster heater +- EK*V3	kVA	(3)							
Minimum Ssc value	Backup heater +-	Booster heater +- EK*Z2	kVA	-		(3)		-		(3)		
Notes	(1)	The above-mentioned power supply of the hydrobox is for the backup heater only.										
	(2)	The optional domestic hot water tank has a separate power supply. In accordance with EN/IEC 61000-3-11, it may be necessary to consult the distribution network operator to ensure that the equipment is connected only to a supply with Zsys ≤ Zmax.										
	(3)	The equipment complies with EN/IEC 61000-3-12.										
	EN/IEC 61000-3-11	European/International Technical Standard setting the limits for voltage changes, voltage fluctuations and flicker in public low-voltage supply systems for equipment with rated current ≤ 75 A.										
EN/IEC 61000-3-12	European/International Technical Standard setting the limits for harmonic currents produced by equipment connected to public low-voltage systems with input current > 16 A and ≤ 75 A per phase.											
Zsys	System impedance											

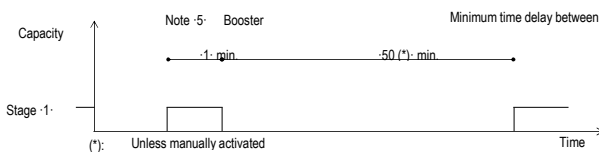
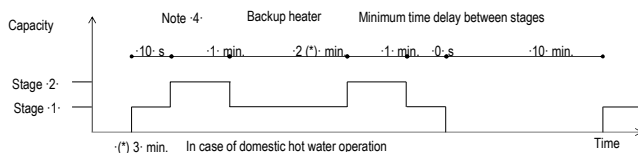

4D121020C

3 Electrical data

3 - 1 Electrical Data

- EBBH-D6V** * Electrical meter specification
- EBBH-D9W** - Pulse meter type/voltage-free contact for 5 V DC detection by PCB.
- EBBX-D6V** - Possible number of pulses
- EBBX-D9W** ·0.1· pulse/kWh
- EBVH-D6V** ·1· pulse/kWh
- EBVH-D9W** ·10· pulse/kWh
- EBVH-UD6V** ·100· pulse/kWh
- EBVX-D6V** ·1000· pulse/kWh
- EBVX-D9W** - Pulse duration
- EBVZ-D6V** minimum On time: ·40ms·
- EBVZ-D9W** Minimum OFF time: ·100ms·
- EBVZ-D6V** - Measurement type (depending on installation)
- EBVZ-D9W** Single-phase AC meter
- Three-phase AC meter
- Balanced loads
- Three-phase AC meter
- Unbalanced loads

* Electrical meter installation guideline

- It is the responsibility of the installer to cover the complete power consumption with electrical meters (combination of estimation and metering is not allowed).
- Required number of electrical meters

Outdoor unit type		ERLA(11/14/16)DA(V3/W1)							
Indoor unit type		EBB(H/X)(11/16)DF*			EBV(H/X/Z)(11/16)S(18/23)DJ*			EBVH16SU23DJ6V	
Backup heater type		6V		9W	6V		9W	6V	
Backup heater power supply		1~ 230V	3~ 230V	3~ 400V	1~ 230V	3~ 230V	3~ 400V	1~ 230V	3~ 230V
Backup heater configuration		2 / 4 / 6 kW	6 kW	3 / 6 / 9 kW	2 / 4 / 6 kW	6 kW	3 / 6 / 9 kW	2 / 4 / 6 kW	6 kW
Normal kWh rate power supply									
Electrical meter type	1~	1	-	-	1	-	-	1	-
	3~ balanced	-	-	-	-	-	-	-	-
	3~ unbalanced	-	1	1	-	1	1	-	1
Preferential kWh rate power supply									
Electrical meter type	1~	2	1	1	2	1	1	2	1
	3~ balanced	-	-	-	-	-	-	-	-
	3~ unbalanced	-	1	1	-	1	1	-	1

4D136477

4 Combination table

4 - 1 Combination Table

4

EBVH-D6V / EBVH-D9W / EBVH-UD6V EBVX-D6V / EBVX-D9W EBVZ-D6V / EBVZ-D9W

Factory-mounted equipment for ·EBV(H/X/Z)(11/16)S*DJ*·

Description	EBV(H/X/Z)(11/16)S(U)*DJ*			
	18 - 6V (11)	18 - 9W (11)	23 - 6V (11)	23 - 9W (11)
Heating only model ·EBVH*·	o	o	o	o
Reversible model ·EBVX*·	o	o	o	o
(Integrated Bizone)	o	o	o	o
Backup heater ·2-4-6kW 1N~230 V·	o	-	o	-
Backup heater ·2-4-6kW 3~230 V·	o	-	o	-
Backup heater ·3-6-9kW 3N~400 V·	-	o	-	o
Domestic hot water tank ·180L·	o	o	-	-
Domestic hot water tank ·230L·	-	-	o	o

Outdoor combination table for ·EBV(H/X/Z)(11/16)S(U)(18/23)DJ(6V/9W)·

		ERLA11DAV3/W1	ERLA14DAV3/W1	ERLA16DAV3/W1
EBVH11S(18/23)DJ*	Heating only indoor unit	o	-	-
EBVX11S(18/23)DJ*	Reversible indoor unit	o	-	-
EBVH16S(18/23)DJ*	Heating only indoor unit	-	o	o
EBVX16S(18/23)DJ*	Reversible indoor unit	-	o	o
EBVZ16S(18/23)DJ*	(Integrated Bizone)	o	o	o
EBVH16SU(18/23)DJ6V	Heating only indoor unit for the UK	o	o	o

Kit availability for indoor units

Reference	Description	EBV(H/X/Z)(11/16)S*DJ*				
		18 - 6V	18 - 9W	23 - 6V	23 - 9W	
EBVH*	Heating only indoor unit	o	o	o	o	
EBVX*	Reversible indoor unit	o	o	o	o	
EBVZ*	(Integrated Bizone)	o	o	o	o	
EBVH16SU23DJ6V	Heating only indoor unit for the UK					U23 - 6V
EKRP1HBAA	Digital I/O PCB	*(1)	(2)	o	o	o
EKRP1AHTA	Demand PCB	*(3)	o	o	o	o
BRC1HHDA	HCI (Human Comfort Interface)	*(4)	o	o	o	o
EKPCAB4	PC cable	o	o	o	o	o
KRCS01-1	Remote indoor sensor	*(5)	o	o	o	o
EKRSCA1	Remote sensor for outdoor	*(5)	o	o	o	o
BRP069A71	WLAN module	o	o	o	o	o
BRP069A78	WLAN cartridge	o	o	o	o	o
EKCC8-W	Universal centralised user interface	o	o	o	o	o
EKHVCONV4	Conversion kit: heating only to reversible.	*(6)	o	o	o	o
EKUHWG3D	·G3· kit	*(7)				o
EKRELSG	Relay for Smart Grid	o	o	o	o	o
FWXV10-15-20ATV3	Heat pump convactor	o	o	o	o	o
FWXT10-15-20ATV3	Heat pump convactor	o	o	o	o	o
FWXM10-15-20ATV3	Heat pump convactor	o	o	o	o	o
EKMIKPOA	Bizone kit	*(8)	o	o	o	o
EKMIKPHA	Bizone kit	*(8)	o	o	o	o
EKWUFHTA1V3	Multi-zoning base unit 230 V	*(9)	o	o	o	o
EKRTR1	Wired room thermostat	o	o	o	o	o
EKRTR1	Wireless room thermostat	o	o	o	o	o
EKRTETS	External sensor room thermostat	*(10)	o	o	o	o

Notes

- (1) PCB that provides additional output connections: · ·
 - (a) Control external heat source (bivalent operation).
 - (b) Output remote ON/OFF signal space heating/cooling
 - (c) Remote alarm output
- (2) Additional relays to allow bivalent control in combination with an external room thermostat are field-supplied.
- (3) PCB to receive up to ·4· digital inputs for power limitation
- (4) Data cable for connection with PC.
- (5) Only 1 remote sensor can be connected: indoor OR outdoor sensor.
- (6) Heating only and bizone indoor unit
- (7) This kit is mandatory for the UK models.
- (8) Only ·EBV(H/X)*· models allowed.
- (9) Multi-zoning wired controls
- (10) ·EKRTETS· can only be used in combination with ·EKRTR1·
- (11) The backup heater capacity depends on a user interface setting.

Remark

Other combinations than mentioned in this combination table are prohibited.

4D128642

5 Capacity tables

5 - 1 Domestic Hot Water performance

EBVH-D6V / EBVH-D9W / EBVH-UD6V
EBVX-D6V / EBVX-D9W
EBVZ-D6V / EBVZ-D9W

Heat-up times

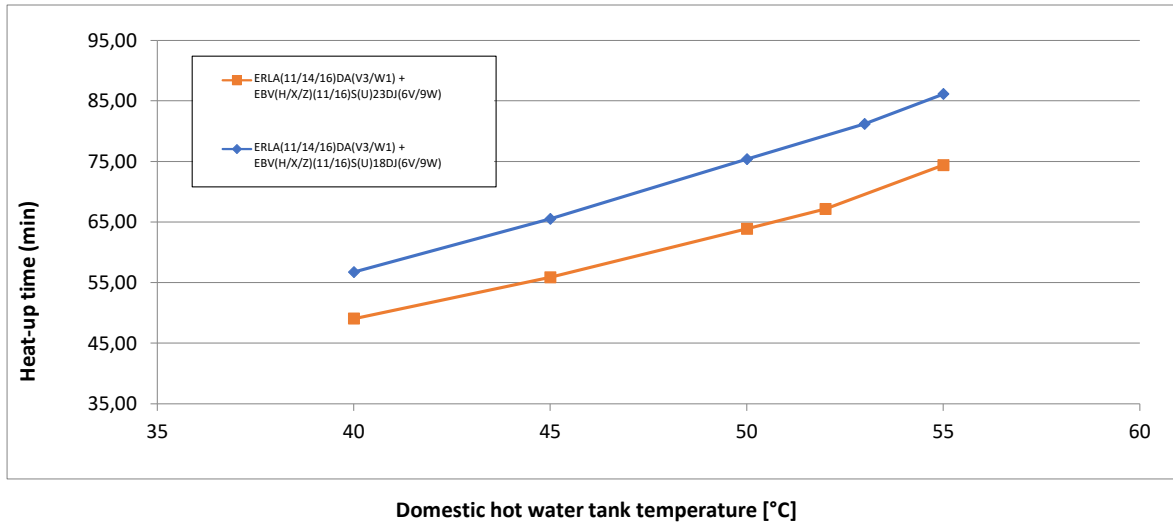

Notes

1. Time the indoor unit (**heat pump only operation**) requires to heat up the domestic hot water tank from 10°C to the indicated temperature.

See the operation range for maximum domestic hot water tank temperature during heat pump only operation.

Model name	Heat-up time domestic hot water tank until 45°C
ERLA(11/14/16)DA(V3/W1) + EBV(H/X/Z)(11/16)S(U)18Dj(6V/9W)	·62· min.
ERLA(11/14/16)DA(V3/W1) + EBV(H/X/Z)(11/16)S(U)23Dj(6V/9W)	·56· min.

Selection guide for the domestic hot water tank volume

- (1) $V_{eq\ 40^\circ C}$ = the amount of water with a temperature of 40°C that can be tapped when the domestic hot water tank is heated to a certain temperature, and the temperature of the cold inlet water is 10°C.

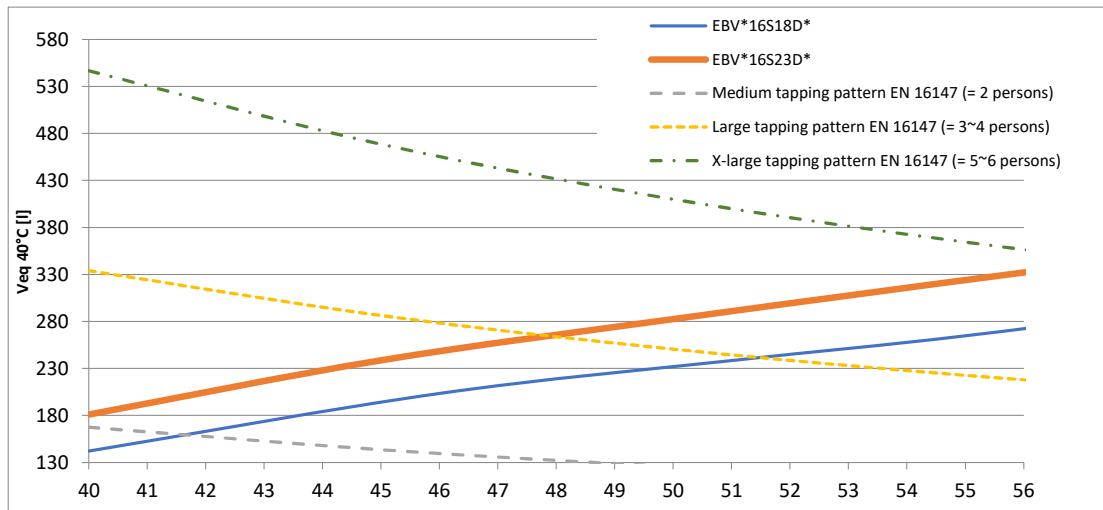

If a higher daily $V_{eq\ 40^\circ C}$ is required, then additional heat-up cycles are required within 24 hours.

See the operation manual for more information.

Notes

- (1) According to EN16147.

4D136698

6 Dimensional drawings

6 - 1 Dimensional Drawings

6

EBVH-D6V
EBVH-D9W
EBVX-D6V
EBVX-D9W

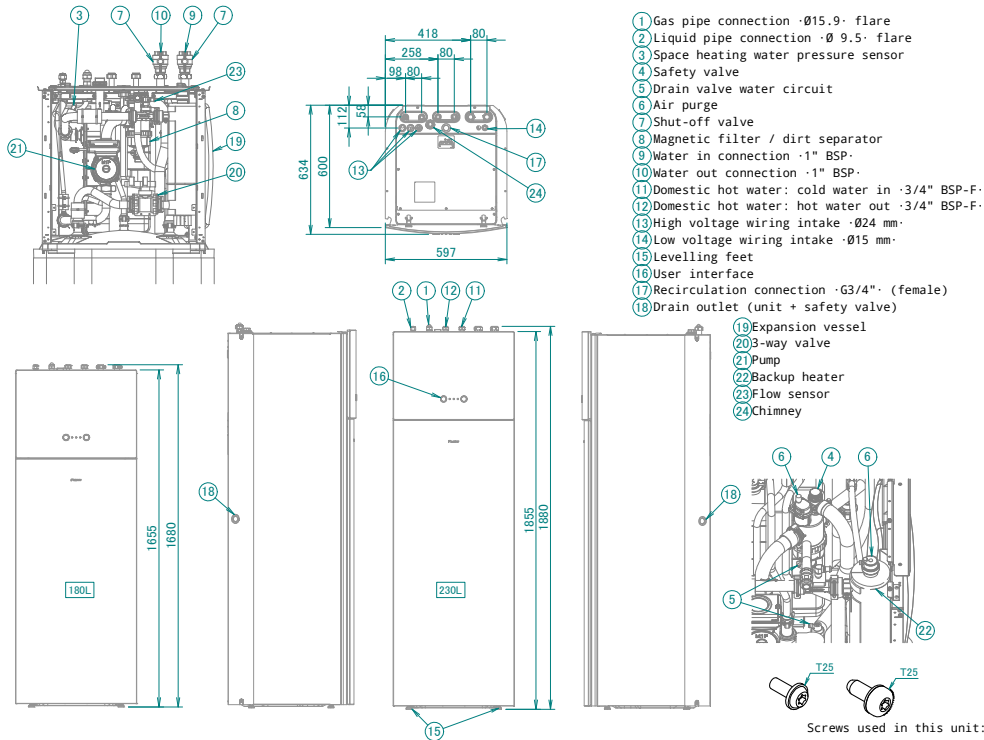

- 1 Gas pipe connection · Ø15.9 · flare
- 2 Liquid pipe connection · Ø 9.5 · flare
- 3 Space heating water pressure sensor
- 4 Safety valve
- 5 Drain valve water circuit
- 6 Air purge
- 7 Shut-off valve
- 8 Magnetic filter / dirt separator
- 9 Water in connection · 1" BSP ·
- 10 Water out connection · 1" BSP ·
- 11 Domestic hot water: cold water in · 3/4" BSP-F ·
- 12 Domestic hot water: hot water out · 3/4" BSP-F ·
- 13 High voltage wiring intake · Ø24 mm ·
- 14 Low voltage wiring intake · Ø15 mm ·
- 15 Levelling feet
- 16 User interface
- 17 Recirculation connection · G3/4" · (female)
- 18 Drain outlet (unit + safety valve)
- 19 Expansion vessel
- 20 3-way valve
- 21 Pump
- 22 Backup heater
- 23 Flow sensor
- 24 Chimney

The typical field installation has to be done according to the applicable legislation. For examples, refer to the installer reference guide.

3D136427A

EBVZ-D6V
EBVZ-D9W

The main zone is the temperature zone with the lowest temperature.
The additional zone is the temperature zone with the highest temperature.

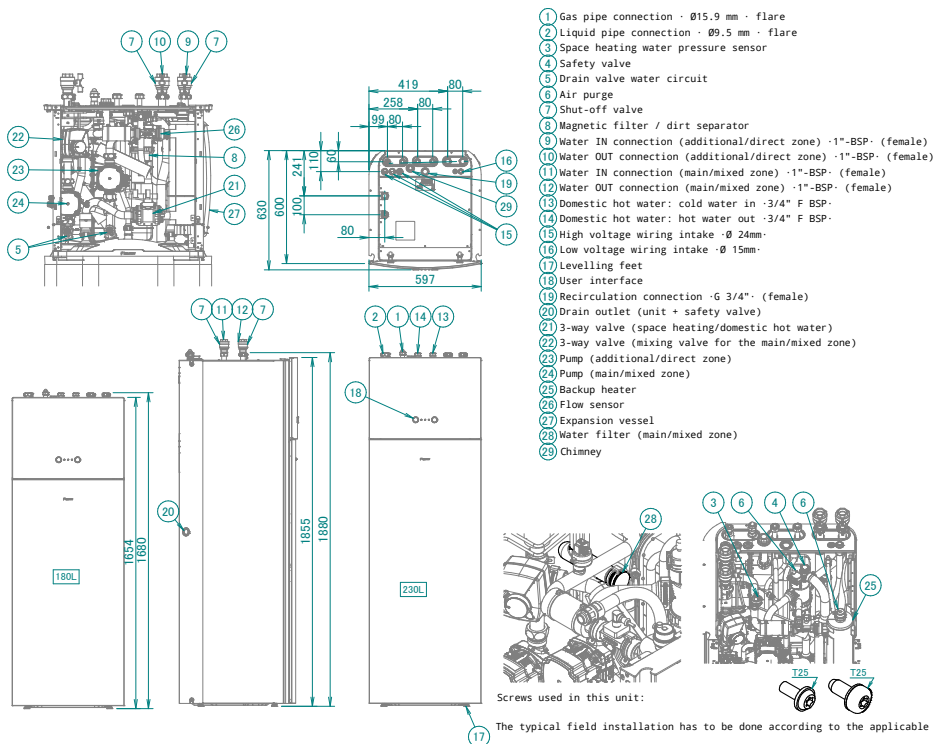

- 1 Gas pipe connection · Ø15.9 mm · flare
- 2 Liquid pipe connection · Ø9.5 mm · flare
- 3 Space heating water pressure sensor
- 4 Safety valve
- 5 Drain valve water circuit
- 6 Air purge
- 7 Shut-off valve
- 8 Magnetic filter / dirt separator
- 9 Water IN connection (additional/direct zone) · 1" ·BSP· (female)
- 10 Water OUT connection (additional/direct zone) · 1" ·BSP· (female)
- 11 Water IN connection (main/mixed zone) · 1" ·BSP· (female)
- 12 Water OUT connection (main/mixed zone) · 1" ·BSP· (female)
- 13 Domestic hot water: cold water in · 3/4" F BSP ·
- 14 Domestic hot water: hot water out · 3/4" F BSP ·
- 15 High voltage wiring intake · Ø 24mm ·
- 16 Low voltage wiring intake · Ø 15mm ·
- 17 Levelling feet
- 18 User interface
- 19 Recirculation connection · G 3/4" · (female)
- 20 Drain outlet (unit + safety valve)
- 21 3-way valve (space heating/domestic hot water)
- 22 3-way valve (mixing valve for the main/mixed zone)
- 23 Pump (additional/direct zone)
- 24 Pump (main/mixed zone)
- 25 Backup heater
- 26 Flow sensor
- 27 Expansion vessel
- 28 Water filter (main/mixed zone)
- 29 Chimney

The typical field installation has to be done according to the applicable legislation. For examples, refer to the installer reference guide.

3D136429A

7 Centre of gravity

7 - 1 Centre of Gravity

EBVH-D6V
 EBVH-D9W
 EBVH-UD6V
 EBVX-D6V
 EBVX-D9W

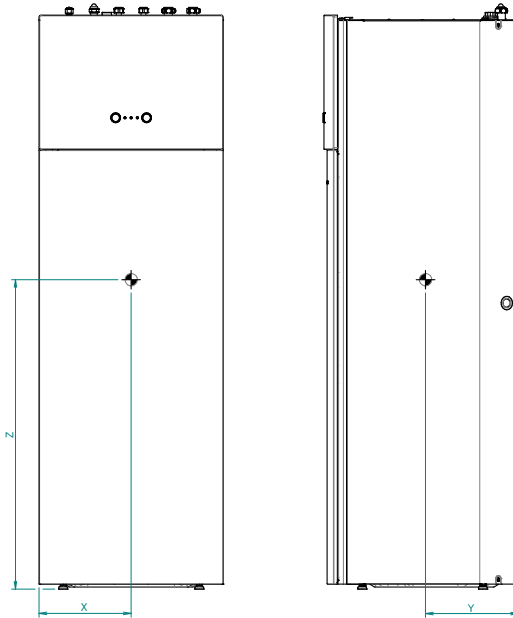

MODEL	X	Y	Z
EBV*S18DJ*	300	290	940
EBV*S (U) 23DJ*	300	295	1070
EBVZ16S18DJ*	290	300	970
EBVZ16S23DJ*	290	305	1090

3D138037

EBVZ-D6V
 EBVZ-D9W

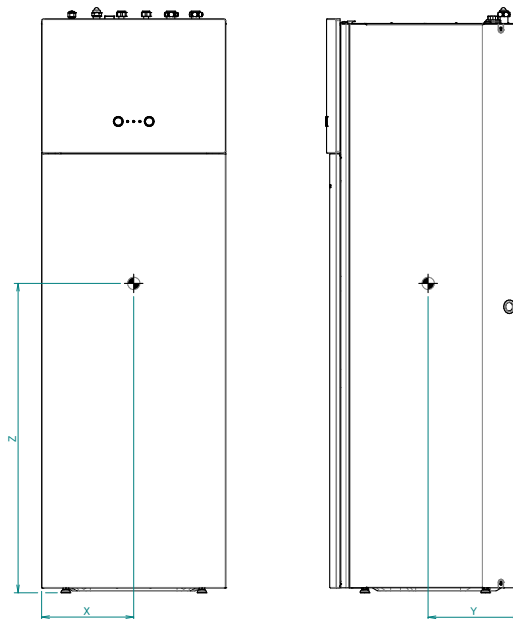

MODEL	X	Y	Z
EBV*S18DJ*	300	290	940
EBV*S (U) 23DJ*	300	295	1070
EBVZ16S18DJ*	290	300	970
EBVZ16S23DJ*	290	305	1090

3D138037

8 Piping diagrams

8 - 1 Piping Diagrams

EBVH-D6V
EBVH-D9W
EBVH-UD6V
EBVX-D6V
EBVX-D9W

- ① Space heating - water OUT
- ② Space heating - water IN
- ③ Domestic hot water: hot water out
- ④ Domestic hot water: cold water in
- ⑤ Recirculation connection
- ⑥ Expansion vessel
- ⑦ Magnetic filter / dirt separator
- ⑧ Safety valve
- ⑨ Air purge
- ⑩ Drain valve
- ⑪ Pump
- ⑫ Plate heat exchanger
- ⑬ Space heating water pressure sensor
- ⑭ Flow sensor
- ⑮ Backup heater
- ⑯ 3-way valve (space heating/domestic hot water)

- ⑰ R1T - Outlet water heat exchanger thermistor
- ⑱ R2T - Outlet water backup heater thermistor
- ⑲ R3T - Thermistor (heat exchanger, liquid pipe)
- ⑳ R4T - Inlet water thermistor
- ㉑ R5T - Tank thermistor
- ㉒ R8T - Tank thermistor
- ㉓ Flexible pipe

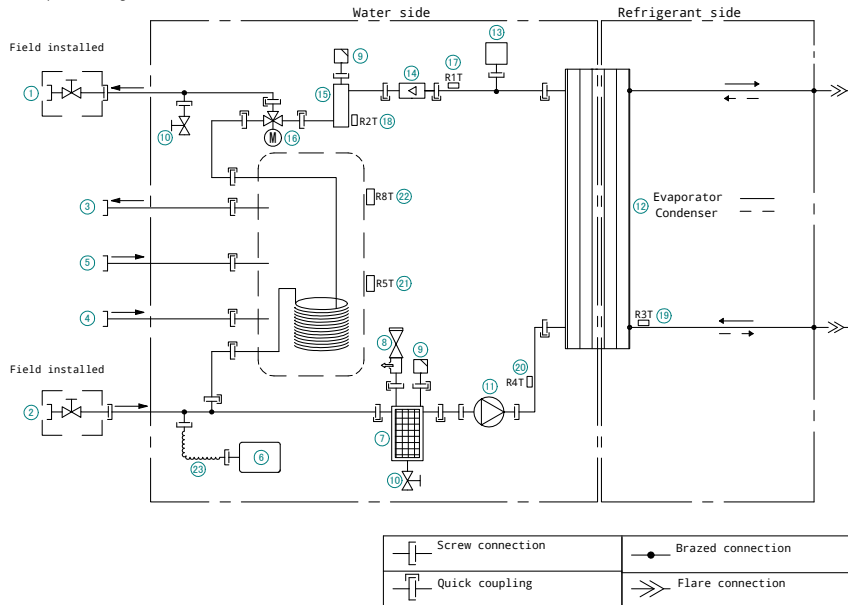

3D128638

EBVZ-D6V
EBVZ-D9W

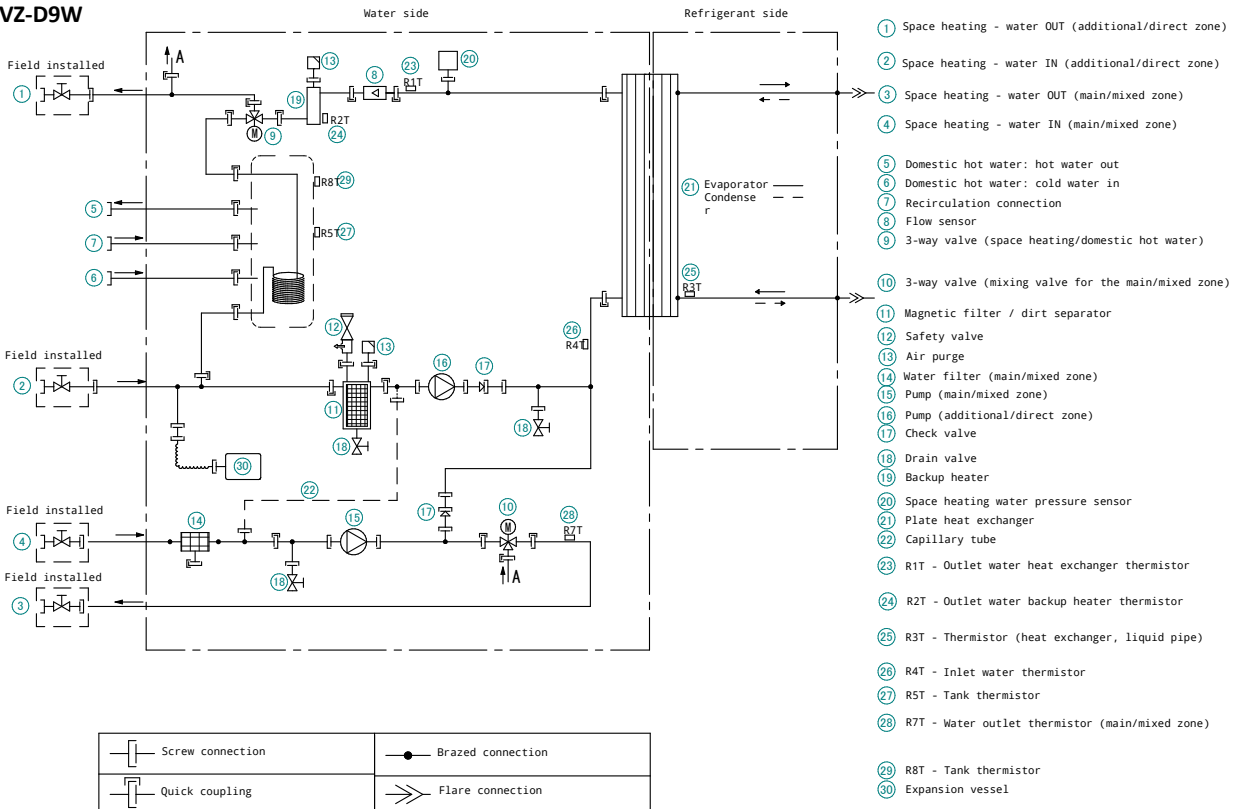

3D128639

9 Wiring diagrams

9 - 1 Notes & Legend

9

EBVH-D6V / EBVH-D9W / EBVH-UD6V / EBVX-D6V / EBVX-D9W

NOTES to go through before starting the unit

- X1M : Main terminal
- X2M : Field wiring terminal for AC
- X5M : Field wiring terminal for DC
- X6M : BUH Power supply terminal
- X10M : Smartgrid terminal
- : Earth wiring
- : Field supply
- ① : Several wiring possibilities
- [] : Option
- [] : Wiring depending on model
- [] : Not mounted in switch box
- [] : PCB

1. Connection point of the power supply for the BUH should be foreseen outside the unit.

- Backup heater power supply
- 6T1 (3~, 230V, 6kW)
 - 6V3 (1N~, 230V, 6kW)
 - 6WN/9WN (3N~, 400V, 6/9kW)
- User installed options:
- Remote user interface
 - Ext. indoor thermistor
 - Ext. outdoor thermistor
 - Digital I/O PCB
 - Demand PCB
 - Safety thermostat
 - Smartgrid kit
 - WLAN adapter module
 - WLAN cartridge
 - Bizone mixing kit
- Main LWT:
- ON/OFF thermostat (wired)
 - ON/OFF thermostat (wireless)
 - Ext. thermistor
 - Heat pump convector
- Add LWT:
- ON/OFF thermostat (wired)
 - ON/OFF thermostat (wireless)
 - Ext. thermistor
 - Heat pump convector

POSITION IN SWITCH BOX

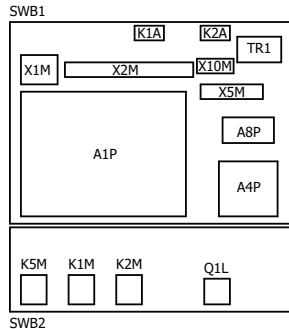

LEGEND

Part n°	Description	Part n°	Description
A1P	main PCB	PHC1 (A4P)	* optocoupler input circuit
A2P	* ON/OFF thermostat (PC=power circuit)	Q1L	thermal protector backup heater
A3P	* heat pump convector	Q4L	# safety thermostat
A4P	* digital I/O PCB	Q*DI	# earth leakage circuit breaker
A8P	* demand PCB	R1H (A2P)	* humidity sensor
A9P	status indicator	R1T (A1P)	outlet water heat exchanger thermistor
A11P	MMI main PCB	R1T (A2P)	* ambient sensor ON/OFF thermostat
A14P	* user interface PCB	R1T (A14P)	* ambient sensor user interface
A15P	* receiver PCB (wireless ON/OFF thermostat)	R2T (A1P)	outlet backup heater thermistor
A20P	* WLAN module	R2T (A2P)	* external sensor (floor or ambient)
A30P	* Bizone mixing kit PCB	R3T	refrigerant liquid side thermistor
B2L	pulse type flow sensor	R4T	inlet water thermistor
B1PW	water pressure sensor	R5T, R8T	domestic hot water thermistor
CN* (A4P)	* connector	R6T	* external indoor or outdoor ambient thermistor
DS1 (A8P)	* dipswitch	S1S	# preferential kWh rate PS contact
E1H	backup heater element (1 kW)	S2S	# electrical meter pulse input 1
E2H	backup heater element (2 kW)	S3S	# electrical meter pulse input 2
E*P (A9P)	indication LED	S4S	# smartgrid feed-in
F1B	# overcurrent fuse backup heater	S6S-S9S	* digital power limitation inputs
F1T	thermal fuse backup heater	S10S-S11S	# low voltage smartgrid contact
F1U, F2U (A4P)	* fuse 5 A 250 V for digital I/O PCB	SS1 (A4P)	* selector switch
FU1 (A1P)	fuse T 5 A 250 V for PCB	SW1~2 (A11P)	turn buttons
K1A, K2A	* high voltage smartgrid relay	SW3~5 (A11P)	push button
K1M, K2M	contactor backup heater	TR1	power supply transformer
K5M	safety contactor BUH	X6M	# BUH power supply terminal strip
K*R (A1P-A4P)	relay on PCB	X10M	* smartgrid power supply terminal strip
M1P	main supply pump	X*, X*A, X*H*, X*Y	connector
M2P	# domestic hot water pump	X*M	terminal strip
M2S	# 2 way valve for cooling mode		
M3S	3 way valve for spaceheating/ domestic hot water		
P1M	MMI display		
PC (A15P)	* power circuit		

* : optional # : field supply

4D126531A

EBVZ-D6V / EBVZ-D9W

NOTES to go through before starting the unit

- X1M : Main terminal
- X2M : Field wiring terminal for AC
- X5M : Field wiring terminal for DC
- X6M : BUH Power supply terminal
- X10M : Smartgrid terminal
- : Earth wiring
- : Field supply
- ① : Several wiring possibilities
- [] : Option
- [] : Not mounted in switch box
- [] : Wiring depending on model
- [] : PCB

Note 1 : Connection point of the power supply for the BUH should be foreseen outside the unit.

- Backup heater power supply
- 6T1 (3~, 230V, 6kW)
 - 6V3 (1N~, 230V, 6kW)
 - 6WN/9WN (3N~, 400V, 6/9kW)
- User installed options:
- Remote user interface
 - Ext. indoor thermistor
 - Ext. outdoor thermistor
 - Digital I/O PCB
 - Demand PCB
 - Safety thermostat
 - Smartgrid
 - WLAN adapter module
 - WLAN cartridge
 - Bizone mixing kit
- Main LWT:
- ON/OFF thermostat (wired)
 - ON/OFF thermostat (wireless)
 - Ext. thermistor
 - Heat pump convector
- Add LWT:
- ON/OFF thermostat (wired)
 - ON/OFF thermostat (wireless)
 - Ext. thermistor
 - Heat pump convector

POSITION IN SWITCH BOX

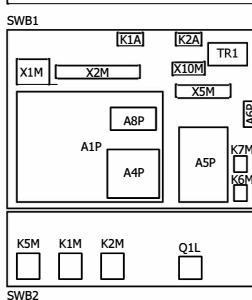

LEGEND

Translation can be found in the installation manual. * : optional # : field supply

Part n°	Description	Part n°	Description
A1P	main PCB	M2S	# 2 way valve for cooling mode
A2P	* On/OFF thermostat (PC=power circuit)	M3P	main zone pump
A3P	* heat pump convector	M3S	3 way valve for space heating /domestic hot water
A4P	* digital I/O PCB	P1M	MMI display
A5P	bizone PCB	PC (A15P)	* power circuit
A6P	current loop PCB	PHC1 (A4P)	* optocoupler input circuit
A8P	* demand PCB	Q1L	thermal protector backup heater
A9P	status indicator	Q3L, Q4L	# safety thermostat
A11P	MMI main PCB	Q*DI	# earth leakage circuit breaker
A14P	* user interface PCB	R1H (A2P)	* humidity sensor
A15P	* receiver PCB (wireless On/OFF thermostat)	R1T (A1P)	outlet water heat exchanger thermistor
A20P	* WLAN module	R1T (A2P)	* ambient sensor On/OFF thermostat
B2L	pulse type flow sensor	R1T (A14P)	* ambient sensor user interface
B1PW	water pressure sensor	R2T (A1P)	outlet backup heater thermistor
CN* (A4P)	* connector	R2T (A2P)	* external sensor (floor or ambient)
DS1 (A8P)	* dipswitch	R3T	refrigerant liquid side thermistor
DS1 (A8P)	* dipswitch	R4T	inlet water thermistor
E1H	backup heater element (1 kW)	R5T, R8T	domestic hot water thermistor
E2H	backup heater element (2 kW)	R6T	* external indoor or outdoor ambient thermistor
E*P (A9P)	indication LED	R7T	mixed leaving water thermistor
F1B	# overcurrent fuse backup heater	S1S	# preferential kWh rate PS contact
F1T	thermal fuse backup heater	S2S	# electrical meter pulse input 1
F1U, F2U (A4P)	* fuse 5 A 250 V for digital I/O PCB	S3S	# electrical meter pulse input 2
F1U, F2U (A5P)	fuse T 3.15 A 250 V for PCB	S4S	# smartgrid feed-in
FU1 (A1P)	fuse T 5 A 250 V for PCB	S6S-S9S	* digital power limitation inputs
K1A, K2A	* high voltage smartgrid relay	S10S-S11S	# low voltage smartgrid contact
K1M, K2M	contactor backup heater	SS1 (A4P)	* selector switch
K5M	safety contactor BUH	SW1~2 (A11P)	turn buttons
K6M	relay 3 way valve bypass	SW3~5 (A11P)	push button
K7M	relay 3 way valve flow	TR1	power supply transformer
K*R (A1P, A4P)	relay on PCB	X6M	# BUH power supply terminal strip
M1P	additional zone pump	X10M	* smartgrid power supply terminal strip
M1S	mixing 3 way valve	X*, X*A, X*H*, X*Y	connector
M2P	# domestic hot water pump	X*M	terminal strip

4D126532B

9 Wiring diagrams

9 - 2 Control Circuit

EBVH-D6V
EBVH-D9W
EBVH-UD6V
EBVX-D6V
EBVX-D9W

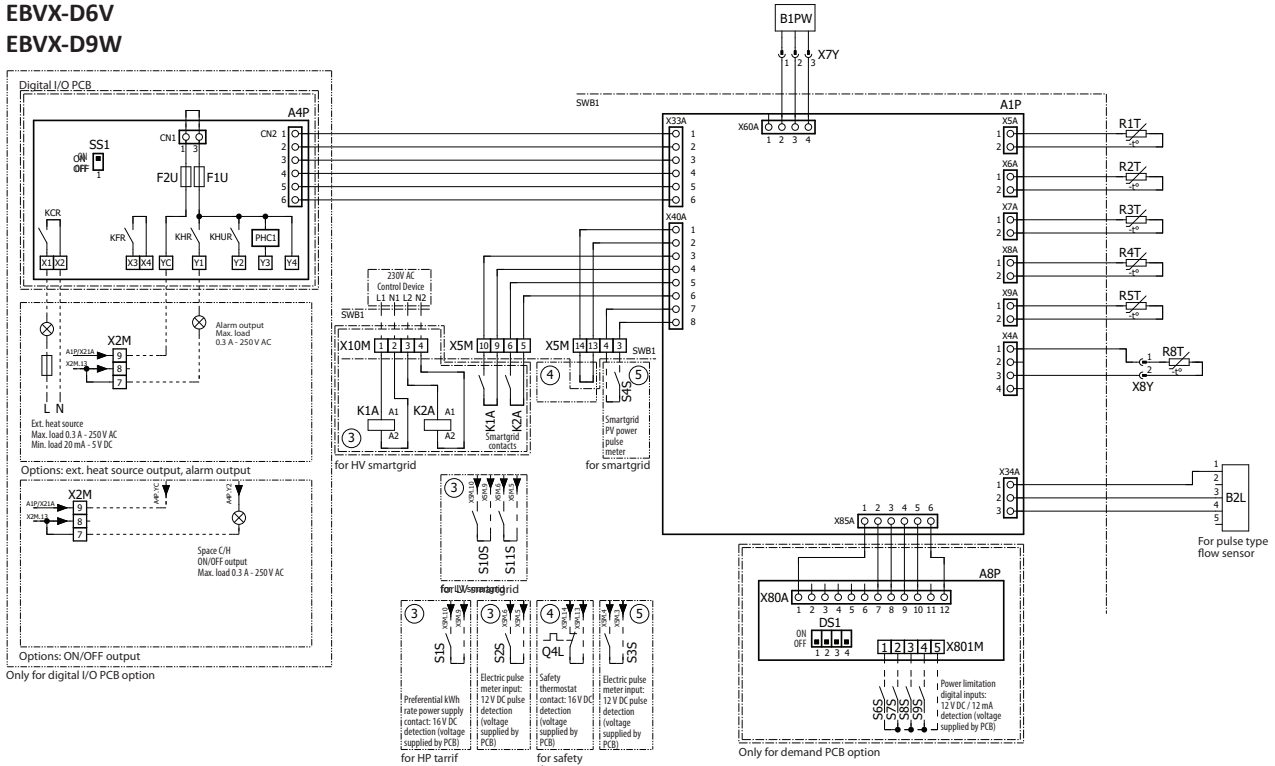

4D126531A

EBVH-D6V
EBVH-D9W
EBVH-UD6V
EBVX-D6V
EBVX-D9W

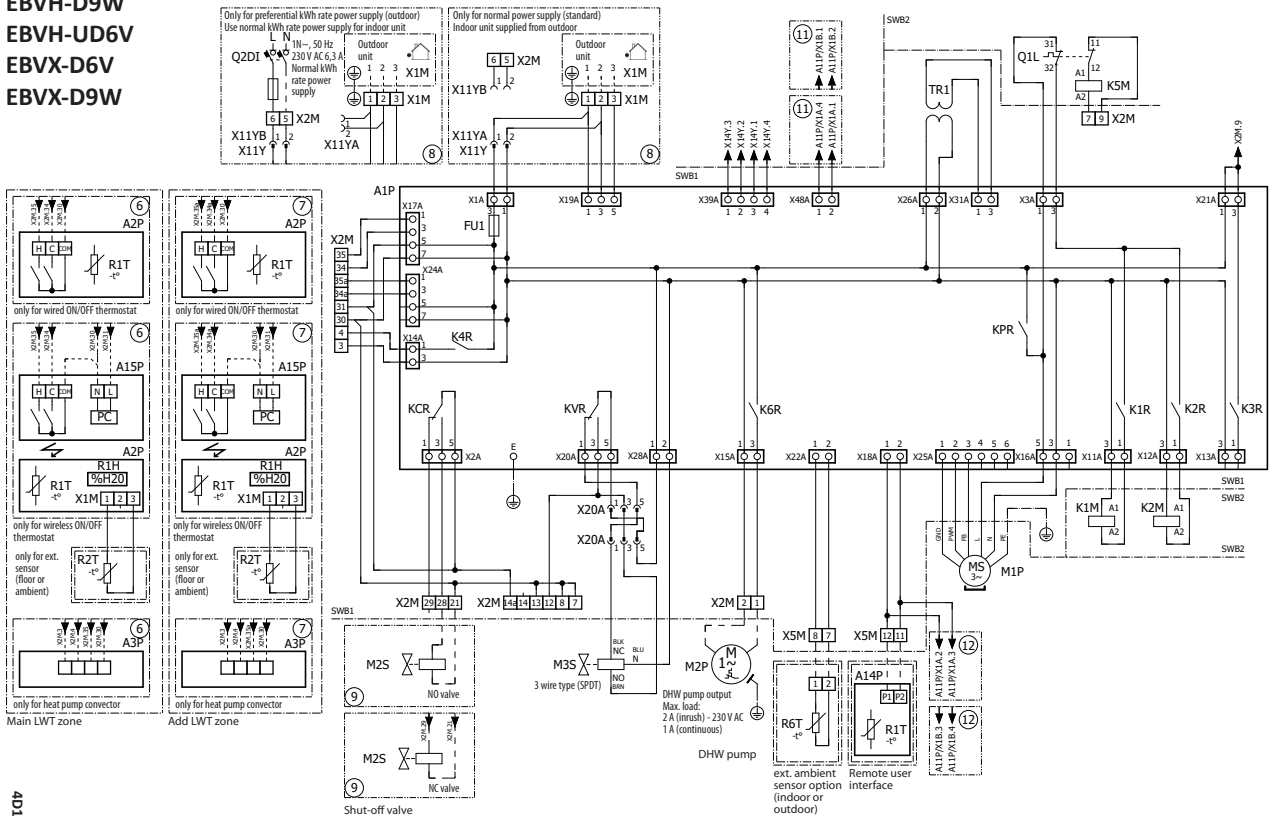

4D126531A

9 Wiring diagrams

9 - 2 Control Circuit

9

EBVH-D6V
EBVH-D9W
EBVH-UD6V
EBVX-D6V
EBVX-D9W

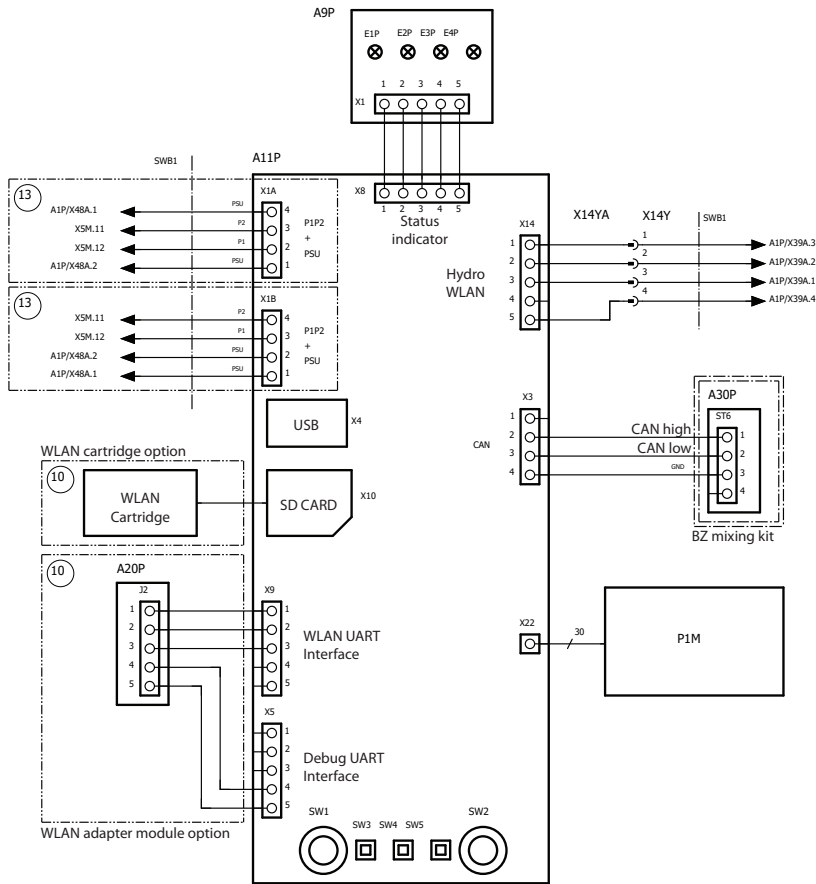

4D126531A

9 Wiring diagrams

9 - 2 Control Circuit

EBVZ-D6V
EBVZ-D9W

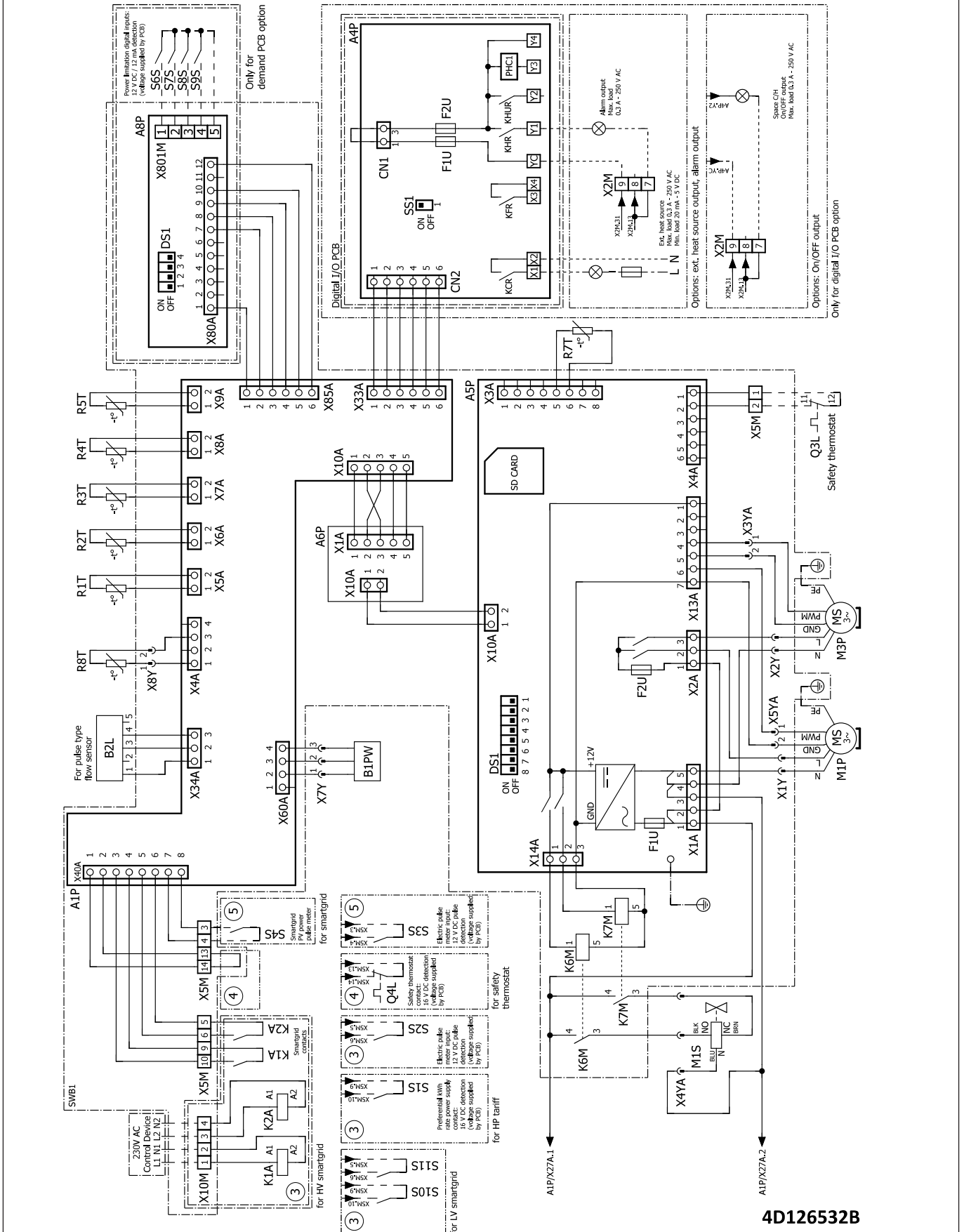

9 Wiring diagrams

9 - 2 Control Circuit

EBVZ-D6V
EBVZ-D9W

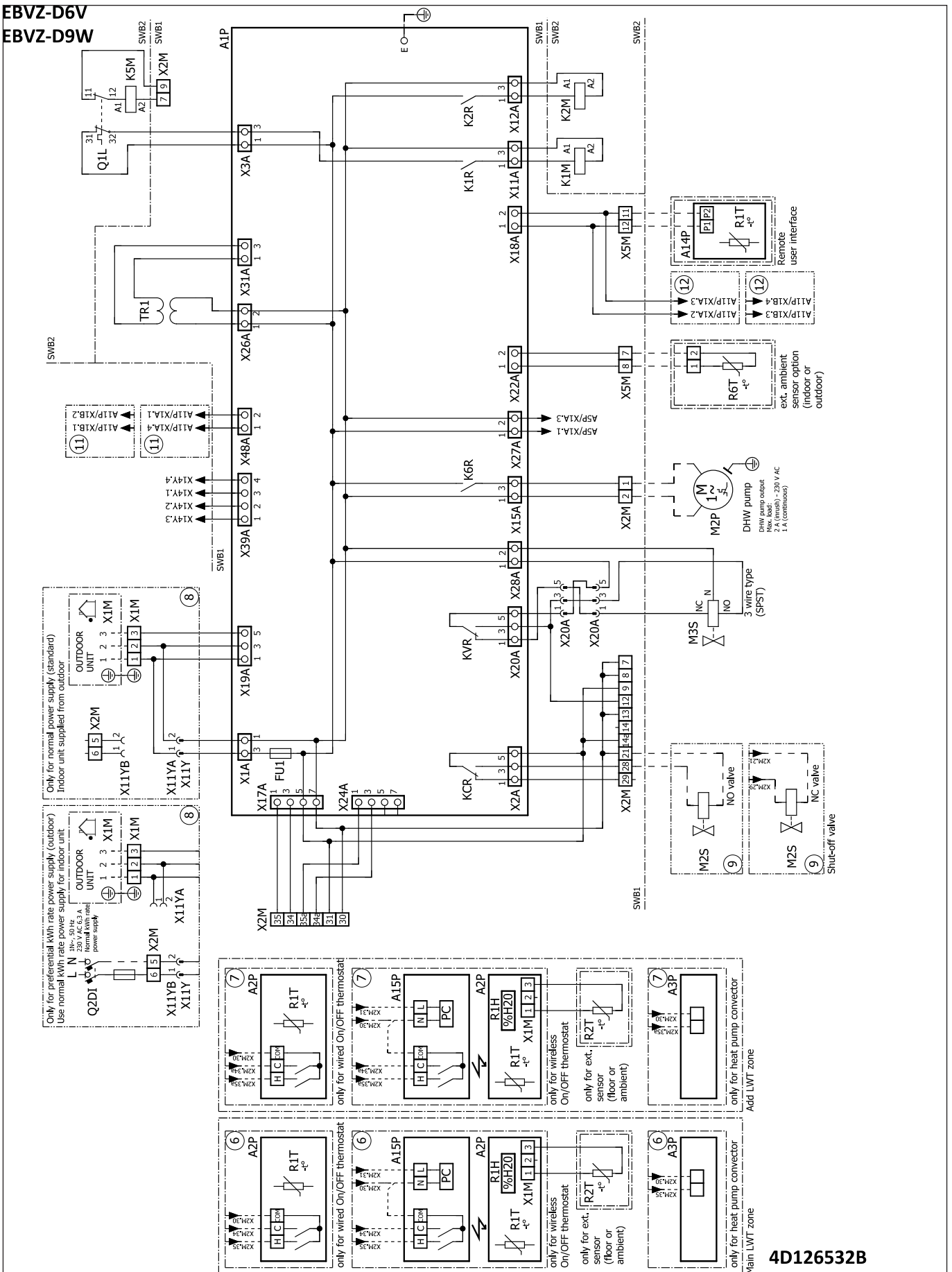

9 Wiring diagrams

9-2 Control Circuit

EBVZ-D6V
EBVZ-D9W

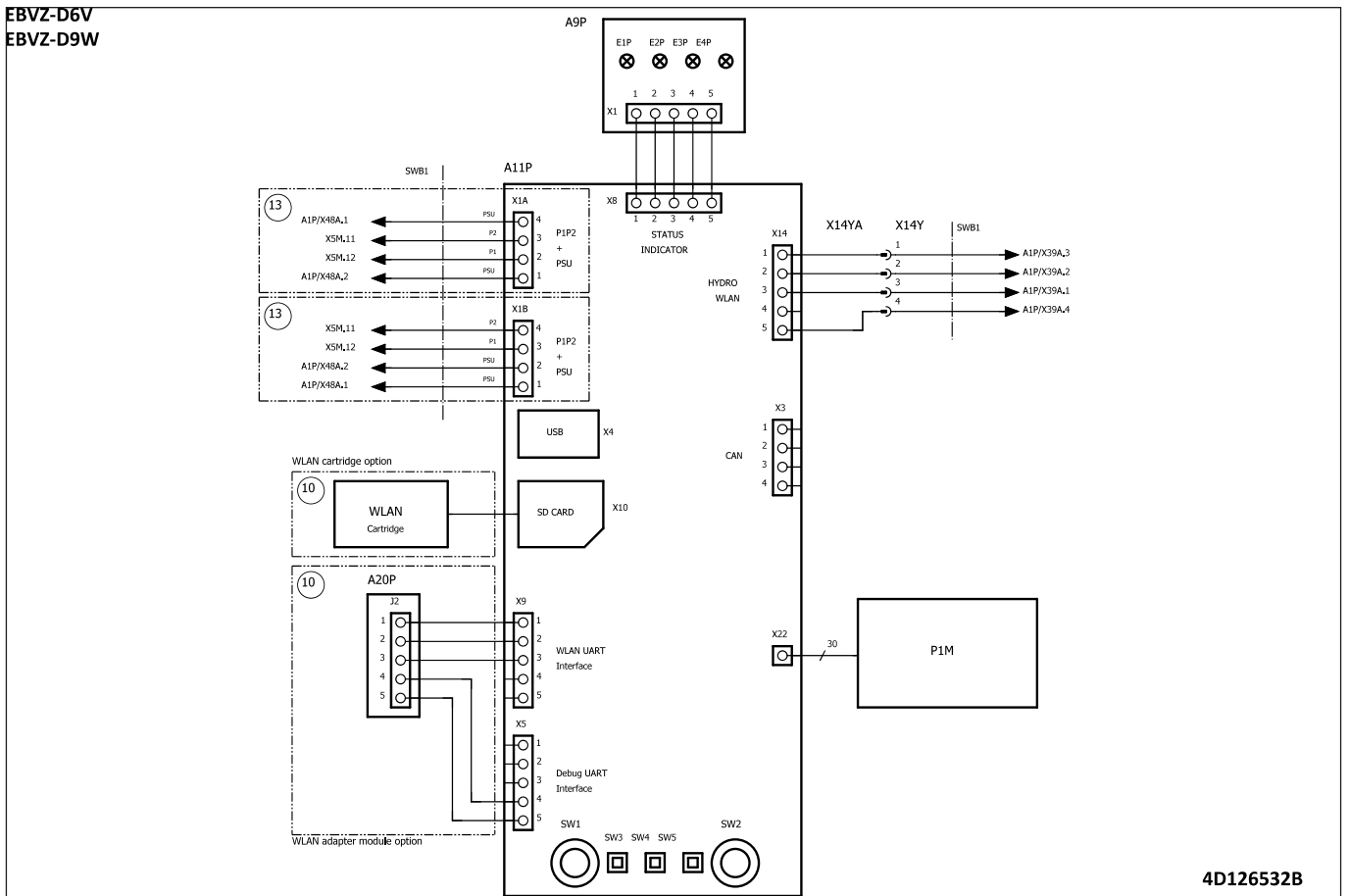

4D126532B

9 Wiring diagrams

9 - 3 Power Supply, Back-up Heater

9

EBVH-D6V
EBVH-D9W
EBVH-UD6V
EBVX-D6V
EBVX-D9W

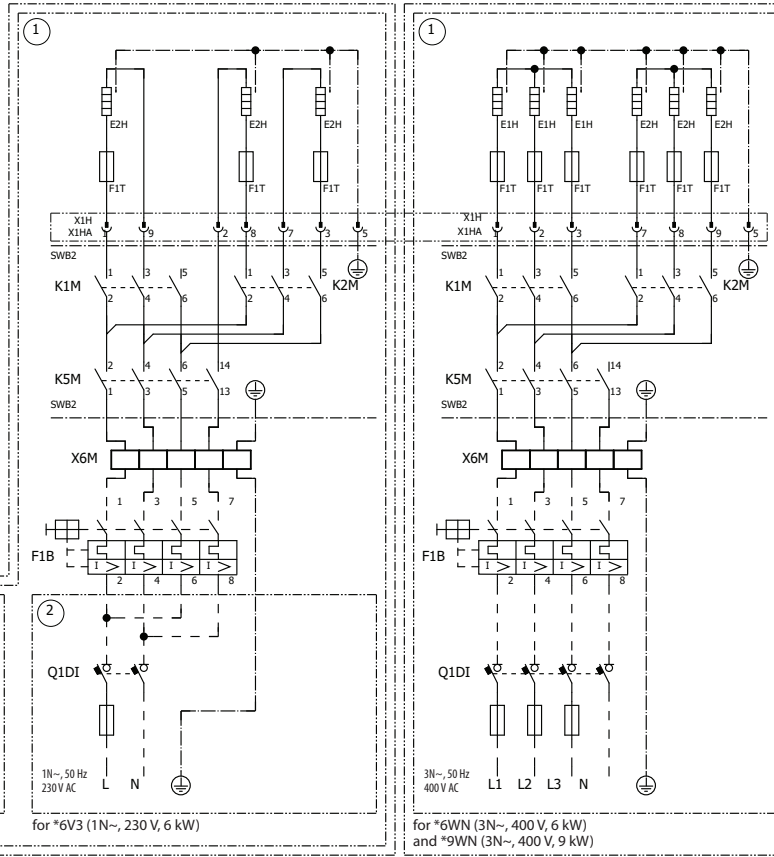
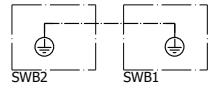

only for *6V

only for *9W

4D126531A

EBVZ-D6V
EBVZ-D9W

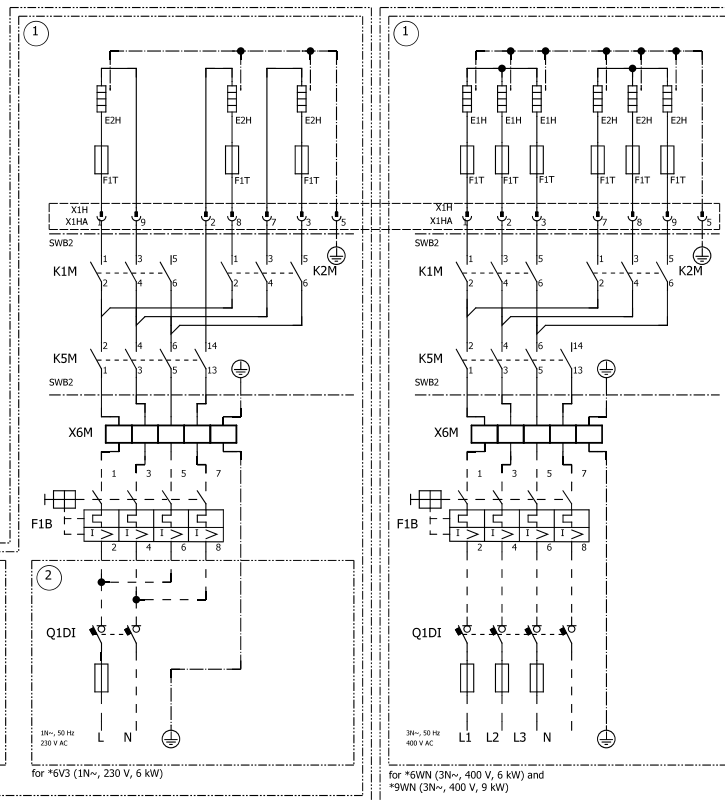
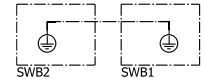

only for *6V

only for *9W

4D126532B

10 External connection diagrams

10-1 External Connection Diagrams

EBVH-D6V
EBVH-D9W
EBVH-UD6V
EBVX-D6V
EBVX-D9W

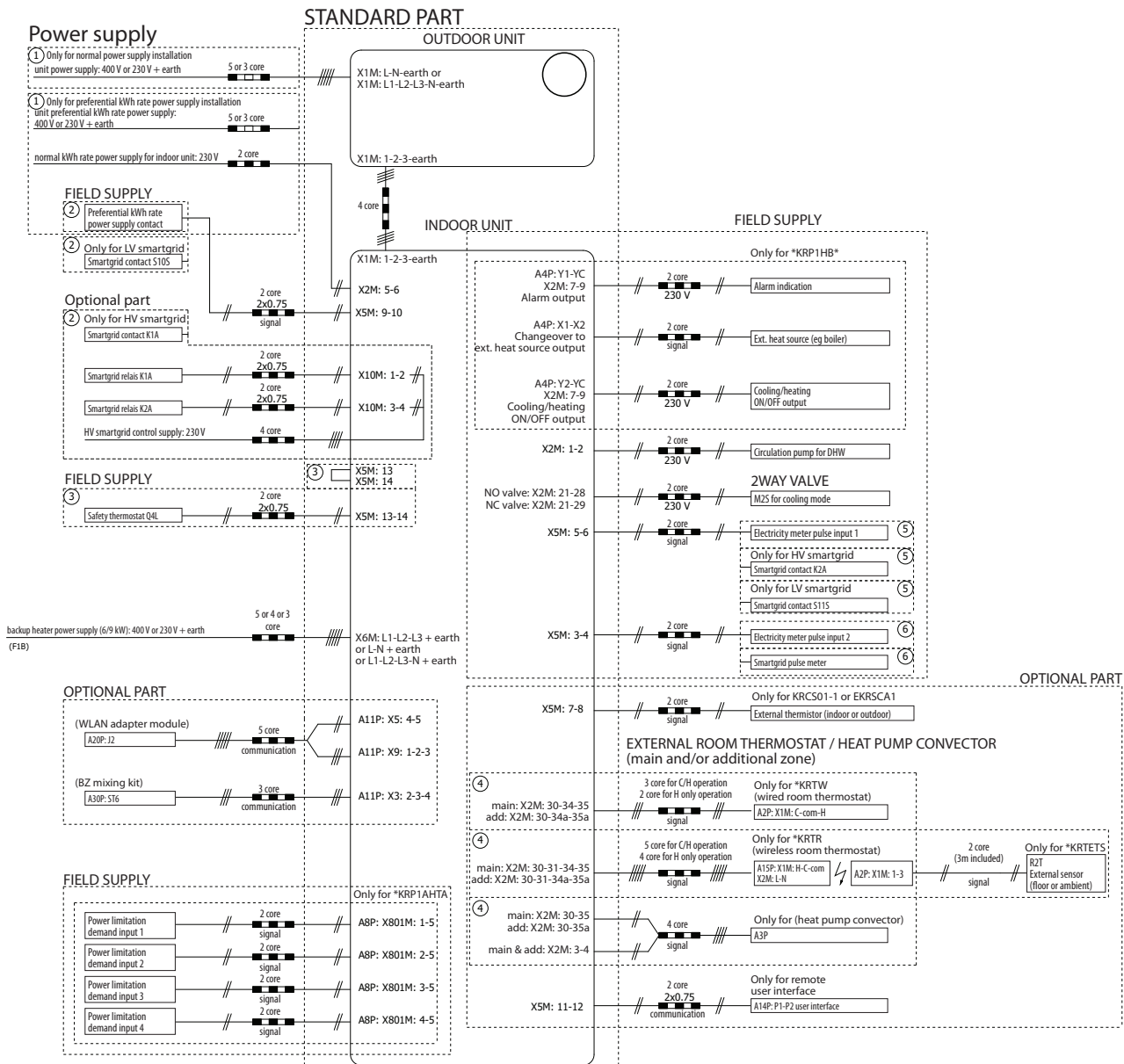

NOTE

- In case of signal cable: keep minimum distance to power cables > 5 cm

4D128798

10 External connection diagrams

10-1 External Connection Diagrams

10

EBVZ-D6V
EBVZ-D9W

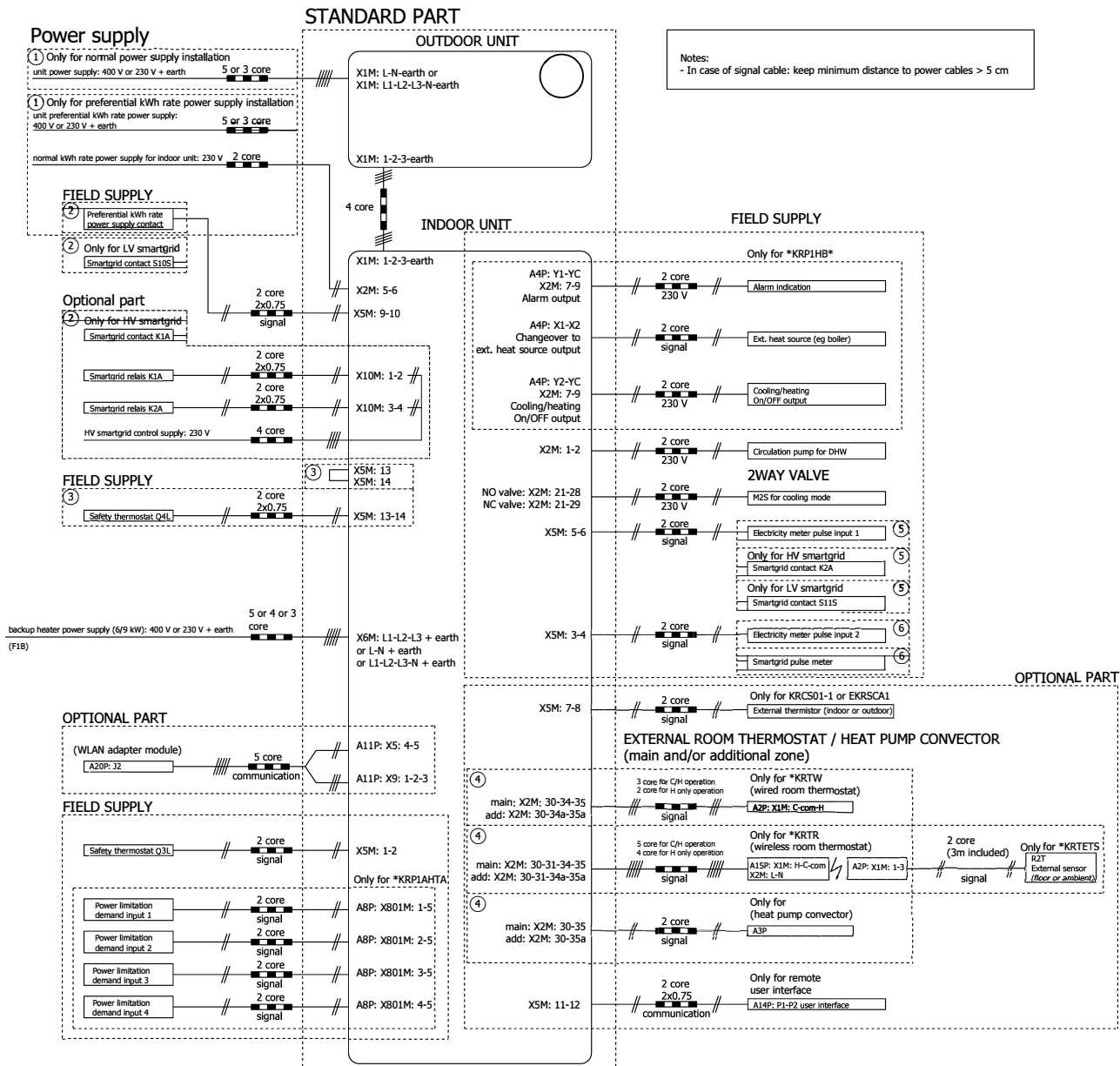

4D128800A

11 Installation

11- 1 Installation Method

- EBVH-D6V**
- EBVH-D9W**
- EBVX-D6V**
- EBVX-D9W**
- EBVZ-D6V**
- EBVZ-D9W**

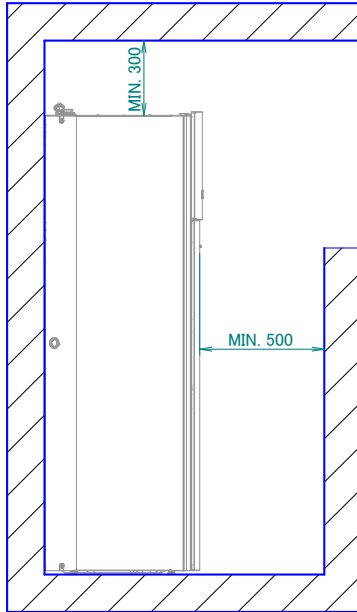
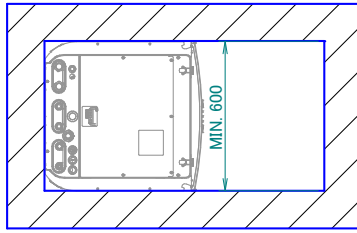

3D136826

12 Operation range

12 - 1 Operation Range

EBBH-D6V
 EBBH-D9W
 EBBX-D6V
 EBBX-D9W
 EBVH-D6V
 EBVH-D9W
 EBVH-UD6V
 EBVX-D6V
 EBVX-D9W
 EBVZ-D6V
 EBVZ-D9W

Legend

- Setpoint [°C]
- Domestic hot water
- Leaving water temperature [°C]
- Pull-up area
- Operation of outdoor unit possible, but with possible capacity reduction.
- Booster heater only operation (if a booster heater is part of the system)

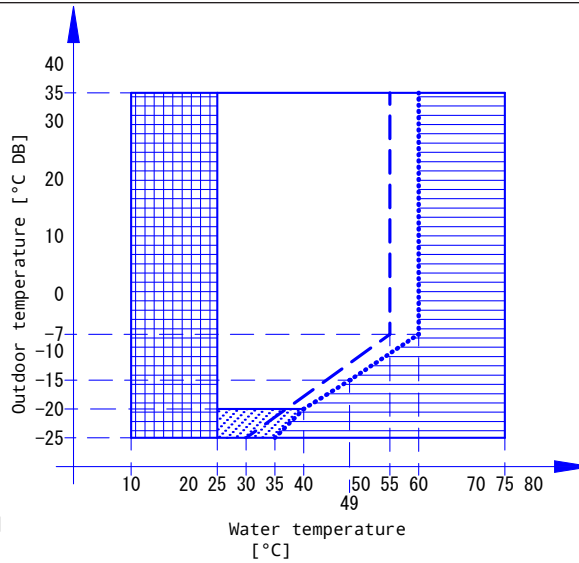

Notes

- In restricted power supply mode (·EKHW*· only), the outdoor unit, booster heater and backup heater can only operate separately.
- Third-party with identical specifications as ·EKHW*·
 Coil surface >·1.05·m² and <·3.7·m²
 Tank thermistor and booster heater above heat pump coil.
- If negative ambient temperatures are expected, both in operation or at standstill, take adequate countermeasures against freezing.
 For more information, refer to the installation manual.

3D130989A

EBBH-D6V / EBBH-D9W / EBBX-D6V / EBBX-D9W
 EBVH-D6V / EBVH-D9W / EBVH-UD6V
 EBVX-D6V / EBVX-D9W / EBVZ-D6V / EBVZ-D9W

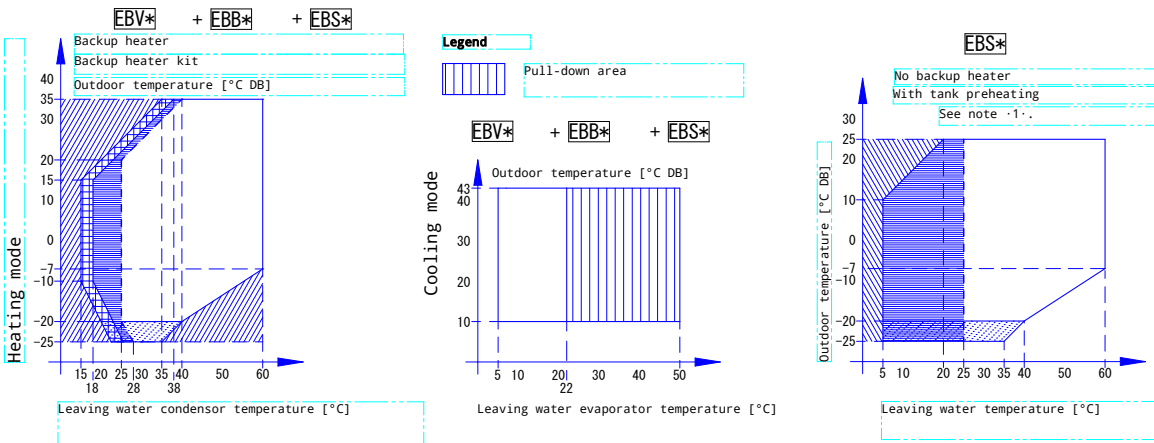

Legend

- Backup heater only operation
- No outdoor unit operation
- Heat pump + backup heater operation
- Pull-up area
- Outdoor unit operation if controller setpoint is regulated to minimal leaving water temperature request.
- See dashed lines
- Operation of outdoor unit possible, but with possible capacity reduction.
- Circulation pump operation only

Notes

- Tank preheating
 For details, see the installer reference guide.
- In restricted power supply mode, the outdoor unit and backup heater can only operate separately.

3D136633A

13 Hydraulic performance

13 - 1 Static Pressure Drop Unit

EBVH11D6V
 EBVH11D9W
 EBVX11D6V
 EBVX11D9W

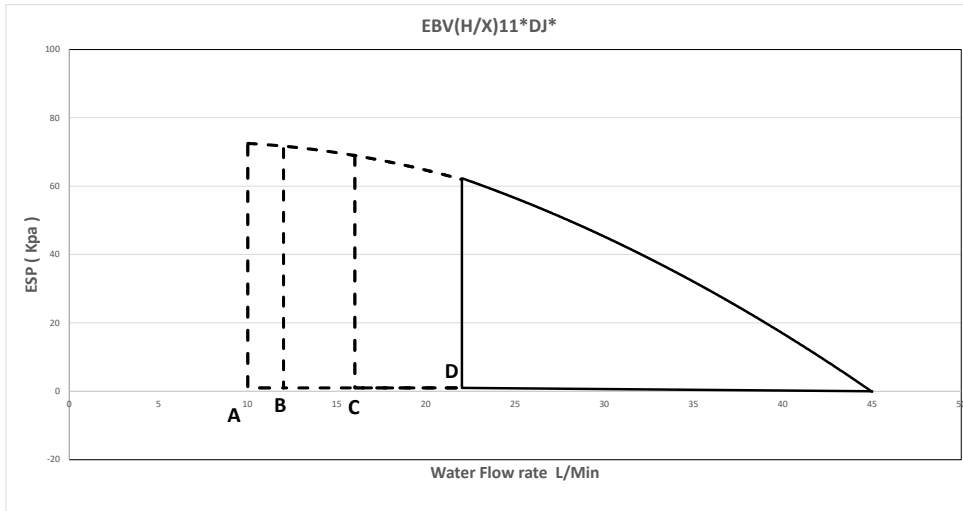

- A = Minimum water flow rate during normal operation
- B = Minimum water flow rate during back up heater operation
- C = Minimum water flow rate during Cooling operation
- D = Minimum water flow rate during Defrost operation

Notes

- 1 Selecting a flow outside the operating area can damage the unit or cause the unit to malfunction.

See also the minimum and maximum allowed water flow range in the technical specifications.

- 2 Water quality must be according to EU directive 2020/2184

4D128634A

EBVH16D6V
 EBVH16D9W
 EBVH16UD6V
 EBVX16D6V
 EBVX16D9W

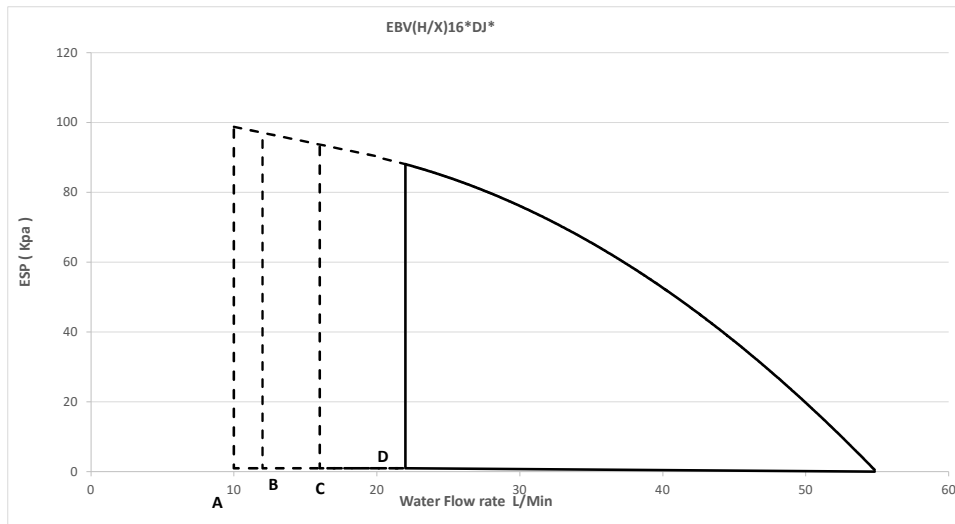

- A = Minimum water flow rate during normal operation
- B = Minimum water flow rate during back up heater operation
- C = Minimum water flow rate during Cooling operation
- D = Minimum water flow rate during Defrost operation

Notes

- 1 Selecting a flow outside the operating area can damage the unit or cause the unit to malfunction.

See also the minimum and maximum allowed water flow range in the technical specifications.

- 2 Water quality must be according to EU directive 2020/2184

4D128635

13 Hydraulic performance

13 - 1 Static Pressure Drop Unit

13

EBVZ-D6V
EBVZ-D9W

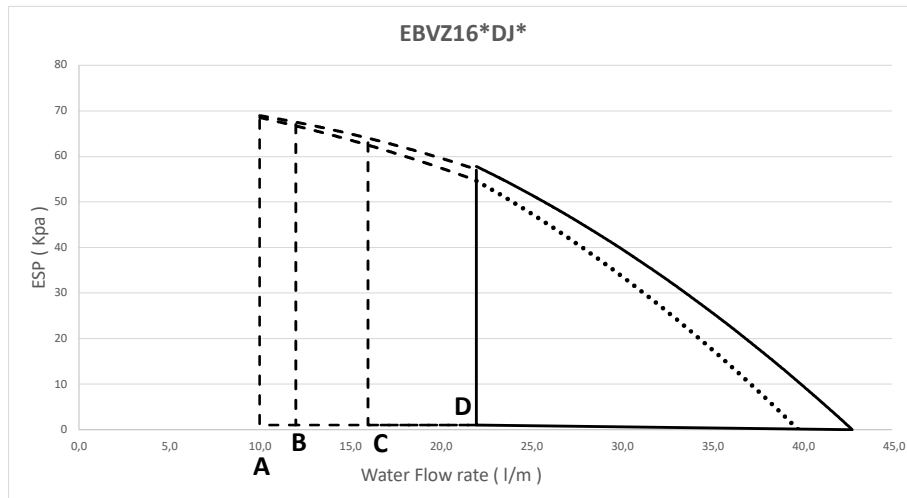

- A= Minimum water flow rate during normal operation
- B= Minimum water flow rate during back up heater operation
- C= Minimum water flow rate during Cooling operation
- D= Minimum water flow rate during Defrost operation

— Additional/direct zone
 Main/mixed zone

Notes

- 1 Selecting a flow outside the operating area can damage the unit or cause the unit to malfunction.

See also the minimum and maximum allowed water flow range in the technical specifications.

- 2 Water quality must be according to EU directive 2020/2184

4D128636A

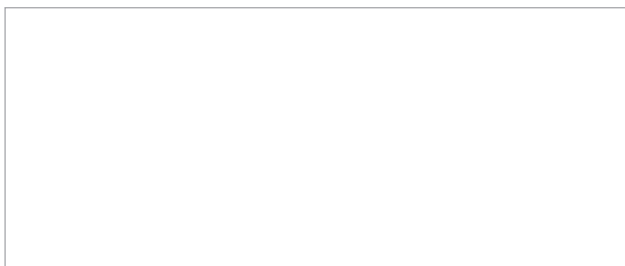

EEEDEN22

02/2022



The present publication is drawn up by way of information only and does not constitute an offer binding upon Daikin Europe N.V. / Daikin Central Europe HandelsGmbH. Daikin Europe N.V. / Daikin Central Europe HandelsGmbH have compiled the content of this publication to the best of their knowledge. No express or implied warranty is given for the completeness, accuracy, reliability or fitness for particular purpose of its content and the products and services presented therein. Specifications are subject to change without prior notice. Daikin Europe N.V. / Daikin Central Europe HandelsGmbH explicitly rejects any liability for any direct or indirect damage, in the broadest sense, arising from or related to the use and/or interpretation of this publication. All content is copyrighted by Daikin Europe N.V.