



Daikin Altherma mid temperature split Technical Data ETVZ12E6V ETVZ12E9W



ETVZ12S18EA6V
ETVZ12S23EA6V
ETVZ12S18EA9W
ETVZ12S23EA9W

TABLE OF CONTENTS

ETVZ12E6V / ETVZ12E9W

1	Features ETVZ12E6V, ETVZ12E9W	4 4
2	Specifications	5
3	Electrical data	10
4	Combination table	12
5	Capacity tables Domestic Hot Water performance	13 13
6	Dimensional drawings	14
7	Centre of gravity	15
8	Piping diagrams	16
9	Wiring diagrams Notes & Legend Control Circuit Power Supply, Back-up Heater	17 17 18 20
10	External connection diagrams	21
11	Installation Installation Method	22 22
12	Operation range	23
13	Hydraulic performance Static Pressure Drop Unit	24 24

1 Features

1 - 1 ETVZ12E6V, ETVZ12E9W

Floor standing unit integrated with different temperature zones management

1

- › Integrated indoor unit: all-in-one floor standing unit including the domestic hot water tank
- › Inclusion of all hydraulic components means no third party components are required
- › The unit's sleek design blends in with other household appliances.
- › Bi-zone allows temperature monitoring for 2 zones. Connect underfloor heating to radiators to optimise efficiency
- › Quick configuration in 9 steps in a high resolution colour interface wizard



Daikin
Residential
Controller
(optional)

2 Specifications

1 - 1 ETVZ12E6V, ETVZ12E9W

Technical specifications				ETVZ12S18E6V		ETVZ12S23E6V	
Heater capacity	Step 1	kW				2	
	Step 2	kW				2 or 4	
Power input	Nom.	kW				0.15	
Casing	Material					Precoated sheet metal	
Dimensions	Unit	Height	mm	1,650		1,850	
		Width	mm			595	
		Depth	mm			625	
	Packed unit	Height	mm	1,820		2,020	
		Width	mm			720	
		Depth	mm			740	
Weight	Unit	kg	114		122		
	Packed unit	kg	133		141		
Packing	Material				Wood / Carton / PE wrapping foil / Metal		
	Weight	kg			16		
Pump Additional Zone	Nr of speeds				PWM		
	Power input	W			60		
	Type				Grundfos UPM3 K 15-75 130 EUX9		
Pump Main Zone	Nr of speeds				PWM		
	Power input	W			60		
	Type				Grundfos UPM3 K 15-75 130 EUX3 PWM		
Water side Heat exchanger	Water flow rate	Min. l/min			20.0 (1)		
Expansion vessel	Volume	l			10		
	Max. water pressure	bar			3		
	Pre pressure	bar			1		
Water Filter Additional Zone	Diameter perforations	mm			0.8		
	Material				Plastic / Stainless steel		
Water filter Main Zone	Diameter perforations	mm			1.0		
	Material				Copper - brass - stainless steel		
Tank	Name		Stainless steel domestic hot water tank 180 l		Stainless steel domestic hot water tank 230 L		
	Water volume	l	180		230		
	Material				Stainless steel (EN 1.4521)		
	Maximum water temperature	°C			70.0		
	Maximum water pressure	bar			10		
	Insulation	Material				Polyurethane foam	
		Heat loss	kWh/24h	1.2 (2)		1.4 (2)	
	Corrosion protection				Pickling		
	Energy efficiency class				B		
	General	Supplier/ Manufacturer details	Name or trademark Name and address			Daikin Europe N.V. Daikin Europe N.V. - Zandvoordestraat 300, 8400 Oostende, Belgium	
3-way valve		Coefficient of flow (kV)	Space heating	m ³ /h	8		
	Domestic hot water tank		m ³ /h	10			
3-way valve mixing	Coefficient of flow (kV)	Bypass	m ³ /h	13			
		Main zone only	m ³ /h	8			
Water circuit	Piping material				Cu		
	Internal piping diameter	inch			1-1/4"		
	Piping	inch			1"		
	Safety valve	bar			3		
	Manometer				Digital		
	Drain valve / fill valve				No		
	Shut off valve				Yes		
	flowswitch				Yes		
	Air purge valve				Yes		
	Total water volume	l			3.5 (3)		
	Minimum water volume in the system for cooling	l			20 (4)		
	Minimum water volume in the system for heating	l			0 (4)		
	Water circuit - space heating side (additional zone)	Air purge valve				Yes	
		Drain valve / fill valve				No	
Manometer					Yes		
Piping connections diameter		inch			G 1" (FEMALE)		
Safety valve		bar			3		
Water circuit - space heating side (main zone)	Shut off valve				Yes		
	Air purge valve				No		
	Manometer				Yes		
	Piping connections diameter	inch			G 1 (FEMALE)		
	Safety valve	bar			Yes		
Shut off valve				Yes			

2 Specifications

1 - 1 ETVZ12E6V, ETVZ12E9W

2

Technical specifications				ETVZ12S18E6V	ETVZ12S23E6V
Water circuit - Domestic hot water side	Piping material			Stainless steel	
	Piping connections	Cold water in / Hot water out inch		G 3/4" FEMALE	
		Recirculation connection inch		G 3/4" FEMALE	
Sound power level	Nom.		dB(A)	44.0 (5)	
Sound pressure level	Nom.		dB(A)	30.0 (6)	
Operation range	Heating	Ambient	Min.	°C	0 (7)
			Max.	°C	0 (7)
Operation range	Heating	Water side	Min.	°C	0 (7)
			Max.	°C	0 (7)
	Indoor installation	Ambient	Min.	°CDB	5
			Max.	°CDB	35 (8)
	Cooling	Ambient	Min.	°CDB	0 (7)
			Max.	°CDB	0 (7)
Water side		Min.	°C	0 (7)	
		Max.	°C	0 (7)	
Domestic hot water side	Min.	°C	0 (7)		
	Max.	°C	0 (7)		
Safety devices	Item	01		Thermal cut out	

Electrical specifications				ETVZ12S18E6V	ETVZ12S23E6V	
Power supply	Name			See note 10		
	Voltage range	Min.	%	10		
		Max.	%	10		
IP class	IP			IP X0B		
Electric heater	Power supply	Name			6V3	
		Phase			1~ / 3~	
		Frequency			Hz	
		Voltage			V	
	Current	Maximum running current			A	
		Zmax	List	Ω	0.22	
Minimum Ssc value			Equipment complying with EN/IEC 61000-3-12			
Recommended fuses			A	20 (9)		
Wiring connections	Communication cable	Quantity			3+GRD	
		Remark			1.5 mm ²	
	Electric meter	Quantity			2	
		Remark			Minimum 0.75 mm ² (5VDC pulse detection)	
	Preferential kWh rate power supply	Quantity			Power: 2	
		Remark			Power 6.3A (Select diameter and type according to national and local regulations)	
	Domestic hot water pump	Quantity			2	
		Remark			Minimum 0.75 mm ² (2A inrush, 1A continuous)	
	For power supply back-up heater	Quantity			Prewired	
		For connection with R6T	Quantity			2
	Remark			Minimum 0.75 mm ²		
	For connection with A3P	Quantity			Depends on thermostat type, cf. installation manual	
		Remark			Voltage: 230V / Max. current: 100mA / Min. 0.75mm ²	
	For connection with M2S	Quantity			2	
Remark			Voltage: 230V / Max. current: 100mA / Min. 0.75mm ²			
For connection with optional	Quantity			4		
	Remark			100 mA, minimum 0.75 mm ²		

(1) Operation area is extended to lower flow rates only in case the unit operates with heat pump only. (Not in startup, no BUH operation, no defrost operation). |

(2) Based on a dT of 45 K |

(3) Including piping + back-up heater; excluding expansion vessel |

(4) Excluding the water in the unit. This minimum water volume is sufficient for most applications. During critical processes extra water may be required. |

(5) Measured with a pressure drop of 10 kPa in the heating system at an operating condition of leaving water 47-55°C in a room with an ambient of 20°C. DB/WB 7°C/6°. |

(6) Value measured in an anechoic room at 1m distance from the unit. It is a relative value, depending on the distance and acoustic environment. The sound pressure level mentioned is measured with a pressure drop of 10 kPa in the heating system at an operatin |

(7) Refer to operation range of the unit. |

(8) Depends on operation mode, refer to installation manual. |

(9) 4 pole 20 A curve 400V tripping class C (refer to wiring diagram) |

(10) Above mentioned power supply of the hydrobox is for the backup heater only. The switch box and the pump of the hydrobox are supplied via the outdoor unit. The optional domestic hot water tank has a separate power supply.

2 Specifications

1 - 1 ETVZ12E6V, ETVZ12E9W

Technical specifications				ETVZ12S18E9W		ETVZ12S23E9W		
Heater capacity	Step 1		kW	3				
	Step 2		kW	max. 6 kW				
Power input	Nom.		kW	0.15				
Casing	Material			Precoated sheet metal				
Dimensions	Unit	Height	mm	1,650		1,850		
		Width	mm	595				
		Depth	mm	625				
	Packed unit	Height	mm	1,820		2,020		
		Width	mm	720				
		Depth	mm	740				
Weight	Unit		kg	114		122		
	Packed unit		kg	133		141		
Packing	Material			Wood / Carton / PE wrapping foil / Metal				
	Weight			kg				
Pump Additional Zone	Nr of speeds			PWM				
	Power input			W				
	Type			Grundfos UPM3 K 15-75 130 EUX9				
Pump Main Zone	Nr of speeds			PWM				
	Power input			W				
	Type			Grundfos UPM3 K 15-75 130 EUX3 PWM				
Water side Heat exchanger	Water flow rate	Min.	l/min	20.0 (1)				
Expansion vessel	Volume			l				
	Max. water pressure			bar				
	Pre pressure			bar				
Water Filter Additional Zone	Diameter perforations			mm				
	Material			Plastic / Stainless steel				
Water filter Main Zone	Diameter perforations			mm				
	Material			Copper - brass - stainless steel				
Tank	Name			Stainless steel domestic hot water tank 180 l		Stainless steel domestic hot water tank 230 L		
	Water volume			l		180		
	Material			Stainless steel (EN 1.4521)				
	Maximum water temperature			°C				
	Maximum water pressure			bar				
	Insulation	Material			Polyurethane foam			
		Heat loss			kWh/24h		1.2 (2)	
	Corrosion protection			Pickling				
Tank	Energy efficiency class			B				
General	Supplier/ Name or trademark			Daikin Europe N.V.				
	Manufacturer details			Name and address				
				Daikin Europe N.V. - Zandvoordestraat 300, 8400 Oostende, Belgium				
3-way valve	Coefficient of flow (kV)	Space heating	m ³ /h	8				
		Domestic hot water tank	m ³ /h	10				
3-way valve mixing	Coefficient of flow (kV)	Bypass	m ³ /h	13				
		Main zone only	m ³ /h	8				
Water circuit	Piping material			Cu				
	Internal piping diameter			inch				
	Piping			inch				
	Safety valve			bar				
	Manometer			Digital				
	Drain valve / fill valve			No				
	Shut off valve			Yes				
	flowswitch			Yes				
	Air purge valve			Yes				
	Total water volume			l				
	Minimum water volume in the system for cooling			l				
	Minimum water volume in the system for heating			l				
	Water circuit - space heating side (additional zone)	Air purge valve			Yes			
		Drain valve / fill valve			No			
Manometer			Yes					
Piping connections diameter			inch					
Safety valve			bar					
Shut off valve			Yes					
Water circuit - space heating side (main zone)	Air purge valve			No				
	Manometer			Yes				
	Piping connections diameter			inch				
	Safety valve			bar				
	Shut off valve			Yes				

2 Specifications

1 - 1 ETVZ12E6V, ETVZ12E9W

2

Technical specifications				ETVZ12S18E9W	ETVZ12S23E9W
Water circuit - Domestic hot water side	Piping material			Stainless steel	
	Piping connections	Cold water in / Hot water out inch		G 3/4" FEMALE	
		Recirculation connection inch		G 3/4" FEMALE	
Sound power level	Nom.		dB(A)	44.0 (5)	
Sound pressure level	Nom.		dB(A)	30.0 (6)	
Operation range	Heating	Ambient	Min.	°C	0 (7)
			Max.	°C	0 (7)
Operation range	Heating	Water side	Min.	°C	0 (7)
			Max.	°C	0 (7)
	Indoor installation	Ambient	Min.	°CDB	5
			Max.	°CDB	35 (8)
	Cooling	Ambient	Min.	°CDB	0 (7)
			Max.	°CDB	0 (7)
Water side		Min.	°C	0 (7)	
		Max.	°C	0 (7)	
Domestic hot water side	Water	Min.	°C	0 (7)	
		Max.	°C	0 (7)	
Safety devices	Item	01		Thermal cut out	

Electrical specifications				ETVZ12S18E9W	ETVZ12S23E9W	
Power supply	Name			See note 10		
	Voltage range	Min.	%	10		
		Max.	%	10		
IP class	IP			IP X0B		
Electric heater supply	Power	Name		9W		
		Phase		3~		
		Frequency	Hz	50		
		Voltage	V	400		
	Current	Maximum running current		A	13.0	
		Recommended fuses		A	20 (9)	
Wiring connections	Communication cable	Quantity		3+GRD		
		Remark		1.5 mm ²		
	Electric meter	Quantity		2		
		Remark		Minimum 0.75 mm ² (5VDC pulse detection)		
	Preferential kWh rate power supply	Quantity		Power: 2		
		Remark		Power 6.3A (Select diameter and type according to national and local regulations)		
	Domestic hot water pump	Quantity		2		
		Remark		Minimum 0.75 mm ² (2A inrush, 1A continuous)		
	For power supply back-up heater	Quantity		Prewired		
		Remark				
	For connection with R6T	Quantity		2		
		Remark		Minimum 0.75 mm ²		
	For connection with A3P	Quantity		Depends on thermostat type, cf. installation manual		
		Remark		Voltage: 230V / Max. current: 100mA / Min. 0.75mm ²		
For connection with M2S	Quantity		2			
	Remark		Voltage: 230V / Max. current: 100mA / Min. 0.75mm ²			
For connection with optional	Quantity		4			
	Remark		100 mA, minimum 0.75 mm ²			

(1) Operation area is extended to lower flow rates only in case the unit operates with heat pump only. (Not in startup, no BUH operation, no defrost operation). |

(2) Based on a dT of 45 K |

(3) Including piping + back-up heater; excluding expansion vessel |

(4) Excluding the water in the unit. This minimum water volume is sufficient for most applications. During critical processes extra water may be required. |

(5) Measured with a pressure drop of 10 kPa in the heating system at an operating condition of leaving water 47-55°C in a room with an ambient of 20°C. DB/WB 7°C/6°. |

(6) Value measured in an anechoic room at 1m distance from the unit. It is a relative value, depending on the distance and acoustic environment. The sound pressure level mentioned is measured with a pressure drop of 10 kPa in the heating system at an operatin |

(7) Refer to operation range of the unit. |

(8) Depends on operation mode, refer to installation manual. |

(9) 4 pole 20 A curve 400V tripping class C (refer to wiring diagram) |

(10) Above mentioned power supply of the hydrobox is for the backup heater only. The switch box and the pump of the hydrobox are supplied via the outdoor unit. The optional domestic hot water tank has a separate power supply.

2 Specifications

1 - 1 ETVZ12E6V, ETVZ12E9W

3 Electrical data

3 - 1 Electrical Data

3

ETVH12E6V / ETVH16E6V / ETVH12UE6V / ETVH16UE6V / ETVH12E9W / ETVH16E9W
 ETVX12E6V / ETVX16E6V / ETVX12E9W / ETVX16E9W
 ETVZ12E6V / ETVZ16E6V / ETVZ12E9W / ETVZ16E9W

Electrical specifications

Type	6V						9W					
	2 - 4		2 - 6		4 - 6		2-4 (in case of emergency: 2-6)			3 - 6 (in case of emergency: 3-9)		
Capacity setting	[kW]											
Capacity stage	2	2	2	2	2	2	1	2	2	2	2	2
Capacity stage 1	2	2	2	2	2	2	6	3	3	3	3	3
Capacity stage 2	4	6	4	4	4	4	-	6	9	6	9	9
Backup heater	Minimum time delay between stages											
	Note 4											
	Power supply (1)											
	Phase											
	Frequency											
	Voltage											
Nominal running current												
Zmax (backup heater)(2)												
Minimum Ssc value												

Notes	Details
(1)	The above-mentioned power supply of the hydrobox is for the backup heater only.
(2)	Booster heater power supply In accordance with EN/IEC 61000-3-11, it may be necessary to consult the distribution network operator to ensure that the equipment is connected only to a supply with Zsys ≤ Zmax.
(3)	The equipment complies with EN/IEC 61000-3-12.
EN/IEC 61000-3-11	European/International Technical Standard setting the limits for voltage changes, voltage fluctuations and flicker in public low-voltage supply systems for equipment with rated current ≤ 75 A.
EN/IEC 61000-3-12	European/International Technical Standard setting the limits for harmonic currents produced by equipment connected to public low-voltage systems with input current > 16 A and ≤ 75 A per phase.
Zsys	System impedance

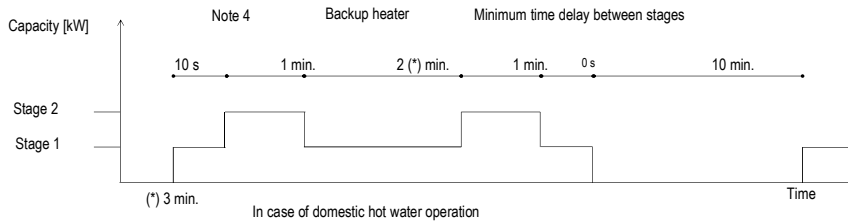

4D121000A

3 Electrical data

3 - 1 Electrical Data

ETBH12E6V / ETBH12E9W / ETBX12E6V / ETBX12E9W
 ETVH12E6V / ETVH12UE6V / ETVH12E9W / ETVX12E6V
 ETVX12E9W / ETVZ12E6V / ETVZ12E9W

* Electrical meter specification

- Pulse meter type/voltage-free contact for 5 V DC detection by PCB.
- Possible number of pulses
 - 0.1· pulse/kWh
 - 1· pulse/kWh
 - 10· pulse/kWh
 - 100· pulse/kWh
 - 1000· pulse/kWh
- Pulse duration
 - minimum On time: ·40ms·
 - Minimum OFF time: ·100ms·
- Measurement type (depending on installation)
 - Single-phase AC meter
 - Three-phase AC meter
 - Balanced loads
 - Unbalanced loads

* Electrical meter installation guideline

- It is the responsibility of the installer to cover the complete power consumption with electrical meters (combination of estimation and metering is not allowed).
- Required number of electrical meters

Outdoor unit type		EPRA(08/10/12)EA*					
Indoor unit type		ETB(H/X)12EF*			ETV(H/X/Z)12S(U)*EA*		
	Backup heater type	6V		9W	6V		9W
	Backup heater power supply	1~ 230V	3~ 230V	3~ 400V	1~ 230V	3~ 230V	3~ 400V
	Backup heater configuration	2 / 4 / 6 kW	6 kW	3 / 6 / 9 kW	2 / 4 / 6 kW	6 kW	3 / 6 / 9 kW
Normal kWh rate power supply							
Electrical meter type	1~	1	-	-	1	-	-
	3~ balanced	-	-	-	-	-	-
	3~ unbalanced	-	1	1	-	1	1
Preferential kWh rate power supply							
Electrical meter type	1~	2	1	1	2	1	1
	3~ balanced	-	-	-	-	-	-
	3~ unbalanced	-	1	1	-	1	1

4D133788

4 Combination table

4 - 1 Combination Table

4

ETVH12E6V / ETVH16E6V / ETVH12UE6V / ETVH16UE6V / ETVH12E9W / ETVH16E9W
 ETVX12E6V / ETVX16E6V / ETVX12E9W / ETVX16E9W
 ETVZ12E6V / ETVZ16E6V / ETVZ12E9W / ETVZ16E9W

Factory-mounted equipment for -ETV(H/X/Z)12S*EA*

Description	ETV(H/X/Z)12S*EA*			
	18 - 6V (8)	18 - 9W (8)	23 - 6V (8)	23 - 9W (8)
Heating only model -ETVH-	o	o	o	o
Reversible model -ETVX-	o	o	o	o
(Integrated Bizone)	o	o	o	o
Backup heater 2-4-6kW 1N~230 V-	o	o	o	o
Backup heater 2-4-6kW 3~230 V-	o	o	o	o
Backup heater 3-6-9kW 3N~400 V-	o	o	o	o
Domestic hot water tank 180L	o	o	o	o
Domestic hot water tank 230L	o	o	o	o

Outdoor combination table for -ETV(H/X/Z)12S(18/23)EA-

		EPR08EA(V3/W1)	EPR10EA(V3/W1)	EPR12EA(V3/W1)
ETVH12S(18/23)EA*	Heating only indoor unit	o	o	o
ETVX12S(18/23)EA*	Reversible indoor unit	o	o	o
ETVZ12S(18/23)EA*	(Integrated Bizone)	o	o	o
ETVH12SU(18/23)EA*	Heating only indoor unit for the UK	o	o	o

Kit availability for indoor units

Reference	Description	ETV*12S*EA*					
		18 - 6V	18 - 9W	23 - 6V	23 - 9W	18 - 6V	23 - 6V
ETVH*	Heating only indoor unit	o	o	o	o		
ETVX*	Reversible indoor unit	o	o	o	o		
ETVZ*	(Integrated Bizone)	o	o	o	o		
ETVH12SU*	Heating only indoor unit for the UK	o	o	o	o		
EKRP1HBAA	Digital I/O PCB	*(1)	o	o	o	o	o
EKRP1AHTA	Demand PCB	*(3)	o	o	o	o	o
BRCHHDA*	HCI (Human Comfort Interface)	o	o	o	o	o	o
EKPCAB4	PC cable	*(4)	o	o	o	o	o
KRCS01-1	Remote indoor sensor	*(5)	o	o	o	o	o
EKRSCA1	Remote sensor for outdoor	*(5)	o	o	o	o	o
EKCC8-W	Universal centralised user interface	o	o	o	o	o	o
DCOM-LT/JO	DCOM gateway	o	o	o	o	o	o
DCOM-LT/MB	DCOM gateway	o	o	o	o	o	o
EKCC8-W	Cascade control	o	o	o	o	o	o
EKHCVN4	Conversion kit: heating only to reversible.	o	o	o	o	o	o
FWXV10-15-20ATV3	Heat pump convactor	*(6)	o	o	o	o	o
FWXT10-15-20ATV3	Heat pump convactor	*(6)	o	o	o	o	o
FWXM10-15-20ATV3	Heat pump convactor	*(6)	o	o	o	o	o
EKVHPC	Heat pump convactor valve kit	o	o	o	o	o	o
EKRTR1A	Wired room thermostat	o	o	o	o	o	o
EKRTR1	Wireless room thermostat	o	o	o	o	o	o
EKRTE5	External sensor room thermostat	*(7)	o	o	o	o	o
EKWUFHTA1V3	Multi-zoning base unit 230 V	*(9)	o	o	o	o	o
EKWCTRD1V3	Digital thermostat 230 V	*(9)	o	o	o	o	o
EKWCTRAN1V3	Analogue thermostat 230 V	*(9)	o	o	o	o	o
EKWCVATR1V3	Actuator 230 V	*(9)	o	o	o	o	o
EKRELSG	Relay for Smart Grid	o	o	o	o	o	o
BRP066A71	WLAN module	*(10)	o	o	o	o	o
EKHJWG3D	45A kit	*(11)	o	o	o	o	o
AFVALVE1	Freeze protection valve	o	o	o	o	o	o
ESAE04A01*	Daikin Residential Controller	o	o	o	o	o	o

Kit availability for outdoor units

Reference	Description	EPR08EA(V3/W1)	EPR10EA(V3/W1)	EPR12EA(V3/W1)
EKMST1	Mounting stand	o	o	o
EKMST2	Mounting stand	o	o	o

Reference	Description		
		ETVH*	ETVX*
	Only applicable for -ETVH* & ETVX*- models		
EKMIKPOA	Mixing kit - PCB only	o	o
EKMIKPHA	Mixing kit - PCB with hydraulics	o	o
EKMIKHMA	Hydraulics - mixed pump group	*(12)	o
EKMIKHUA	Hydraulics - unmixed pump group	*(12)	o
EKMIKBVA	Balancing vessel	o	o
EKMIKDIA	Distributor for balancing vessel	*(13)	o

Notes

- (1) PCB that provides additional output connections:
 - (a) Control external heat source (bivalent operation).
 - (b) Output remote ON/OFF signal space heating/cooling
 - (c) Remote alarm output
- (2) Additional relays to allow bivalent control in combination with an external room thermostat are field-supplied.
- (3) PCB to receive up to 4- digital inputs for power limitation
- (4) Data cable for connection with PC.
- (5) Only 1 remote sensor can be connected: indoor OR outdoor sensor.
- (6) The valve kit is mandatory if a heat pump convactor is installed on a reversible model (not mandatory for heating only models).
- (7) -EKRTETS- can only be used in combination with -EKRTR1-
- (8) The backup heater capacity depends on a user interface setting.
- (9) Multi-zoning wired controls
- (10) The WLAN cartridge is supplied in the accessory bag of the unit and is meant to be plugged into the SD card slot on the MMI-2. In case of bad signal reception, the WLAN cartridge can be removed and replaced by the WLAN module.
- (11) This kit is mandatory for the UK models.
- (12) Only possible in combination with -EKMIKPOA-
- (13) Only possible in combination with -EKMIKBVA- and -EKMIKPHA- or -EKMIKHUA-
- (14) Only possible in combination with -HBKIT*-
- (15) Only possible in combination with -ETVZ*-

Remark
 Other combinations than mentioned in this combination table are prohibited.

4D133479B

5 Capacity tables

5 - 1 Domestic Hot Water performance

ETBH12E6V / ETBH12E9W
 ETBX12E6V / ETBX12E9W
 ETVH12E6V / ETVH12UE6V
 ETVH12E9W / ETVX12E6V
 ETVX12E9W / ETVZ12E6V
 ETVZ12E9W

Heat-up times

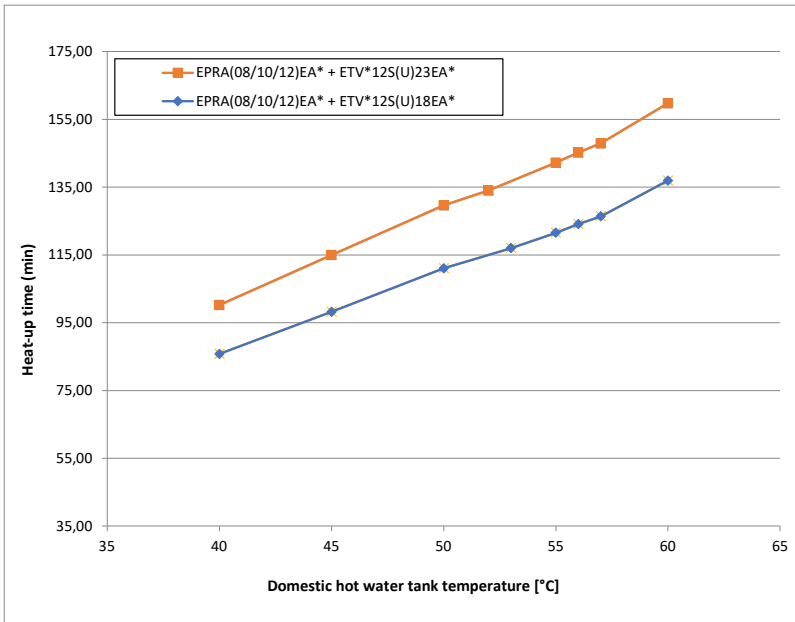

Notes

- Time the indoor unit (**heat pump only operation**) requires to heat up the domestic hot water tank from 10°C to the indicated temperature.
 See the operation range for maximum domestic hot water tank temperature during heat pump only operation.

Model name	Heat-up time domestic hot water tank until 45°C
EPRA(08/10/12)EA* + ETV*12S(U)18EA*	~98 min.
EPRA(08/10/12)EA* + ETV*12S(U)23EA*	~115 min.

4D133480

ETBH12E6V / ETBH12E9W / ETBX12E6V / ETBX12E9W
 ETVH12E6V / ETVH12UE6V / ETVH12E9W / ETVX12E6V
 ETVX12E9W / ETVZ12E6V / ETVZ12E9W

Selection guide for the domestic hot water tank volume

(1)

Ve_q 40°C is the amount of water with a temperature of 40°C that can be tapped when the domestic hot water tank is heated to a certain temperature, and the temperature of the cold inlet water is 10°C.

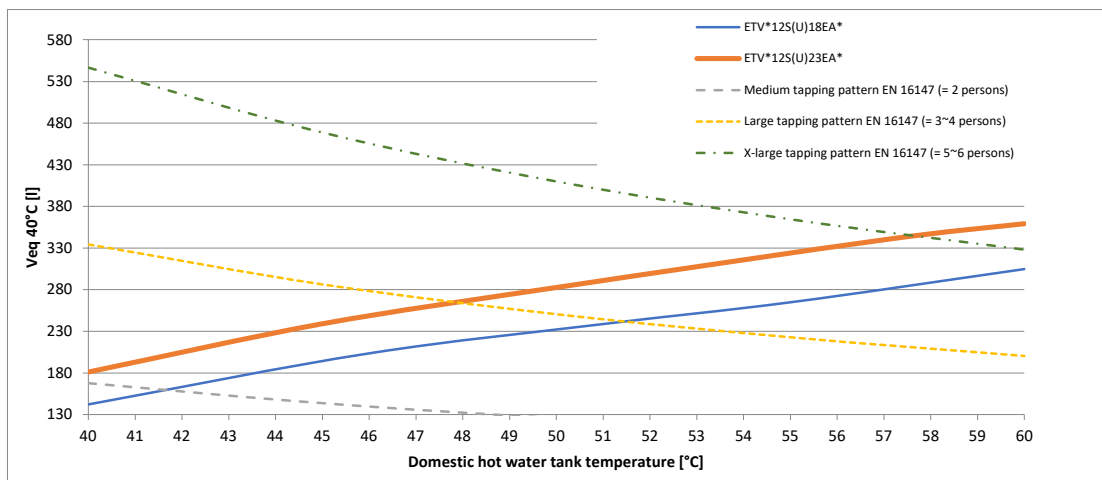

If a higher daily Ve_q 40°C is required, then additional heat-up cycles are required within 24 hours.
 See the operation manual for more information.

Notes

- According to EN16147.

4D133480

6 Dimensional drawings

6 - 1 Dimensional Drawings

ETVZ12E6V / ETVZ12E9W

The additional zone is the temperature zone with the highest temperature.
The main zone is the temperature zone with the lowest temperature.

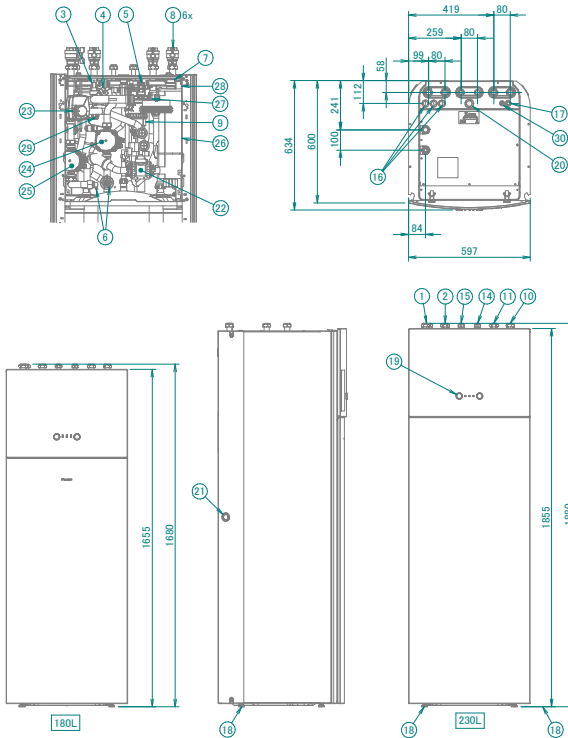

- ① Water out connection ·1"·
- ② Water in connection ·1"·
- ③ Flow switch
- ④ Space heating water pressure sensor
- ⑤ Safety valve
- ⑥ Drain valve water circuit
- ⑦ Air purge
- ⑧ Shut-off valve
- ⑨ Magnetic filter / dirt separator (additional/direct zone)
- ⑩ Water IN connection (additional/direct zone) ·1" F BSP· (female)
- ⑪ Water OUT connection (additional/direct zone) ·1" F BSP· (female)
- ⑫ Water IN connection (main/mixed zone) ·1" F BSP· (female)
- ⑬ Water OUT connection (main/mixed zone) ·1" F BSP· (female)
- ⑭ Domestic hot water: cold water in ·3/4" F BSP·
- ⑮ Domestic hot water: hot water out ·3/4" F BSP·
- ⑯ High voltage wiring intake Ø 24mm
- ⑰ Low voltage wiring intake Ø 15mm
- ⑱ Levelling feet
- ⑲ User interface
- ⑳ Recirculation connection ·G 3/4"· (female)
- ㉑ Drain outlet (unit + safety valve)
- ㉒ 3-way valve (space heating/domestic hot water)
- ㉓ 3-way valve (mixing valve for the main/mixed zone)
- ㉔ Pump (additional/direct zone)
- ㉕ Pump (main/mixed zone)
- ㉖ Backup heater
- ㉗ Flow sensor
- ㉘ Expansion vessel
- ㉙ Water filter (main/mixed zone)
- ㉚ Low voltage wiring intake (options)

To outdoor unit

Screws used in this unit:

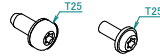

The typical field installation has to be done according to the applicable legislation. For examples, refer to the installer reference guide.

3D133389

7 Centre of gravity

7 - 1 Centre of Gravity

ETVH12E6V / ETVH16E6V / ETVH12UE6V / ETVH16UE6V / ETVH12E9W / ETVH16E9W
 ETVX12E6V / ETVX16E6V / ETVX12E9W / ETVX16E9W
 ETVZ12E6V / ETVZ16E6V / ETVZ12E9W / ETVZ16E9W

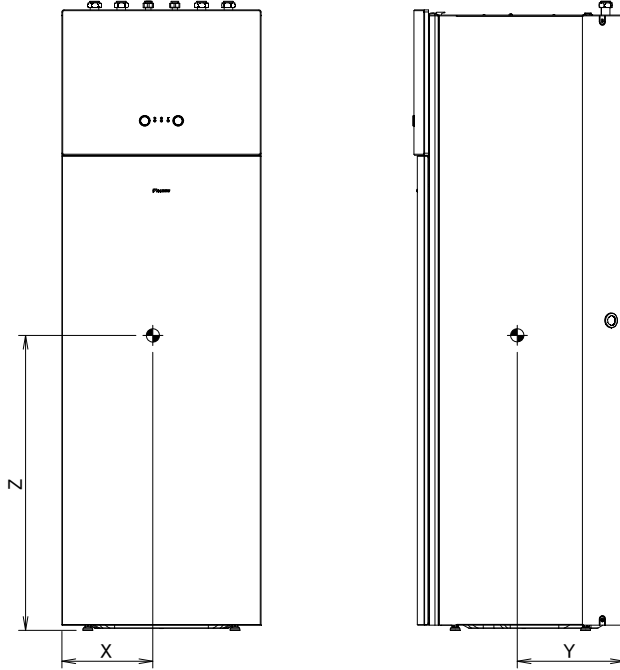

MODEL	X	Y	Z
EAV (H/X) 16S18*	327	329	890
EAV (H/X) 16S23*	327	329	1015
EAVZ16S18*	311	315	903
EAVZ16S23*	311	315	1028
ETV (H/X) 16S18*	327	329	890
ETV (H/X) 16S23*	327	329	1015
ETVZ16S18*	311	315	903
ETVZ16S23*	311	315	1028
ETV (H/X) 12S18*	327	329	890
ETV (H/X) 12S23*	327	329	1015
ETVZ12S18*	311	315	903
ETVZ12S23*	311	315	1028
ETVH12SU18*	327	329	890
ETVH12SU23*	327	329	1015
ETVH16SU18*	327	329	890
ETVH16SU23*	327	329	1015

3D121014D

8 Piping diagrams

8 - 1 Piping Diagrams

8

ETVZ12E6V / ETVZ16E6V
ETVZ12E9W / ETVZ16E9W

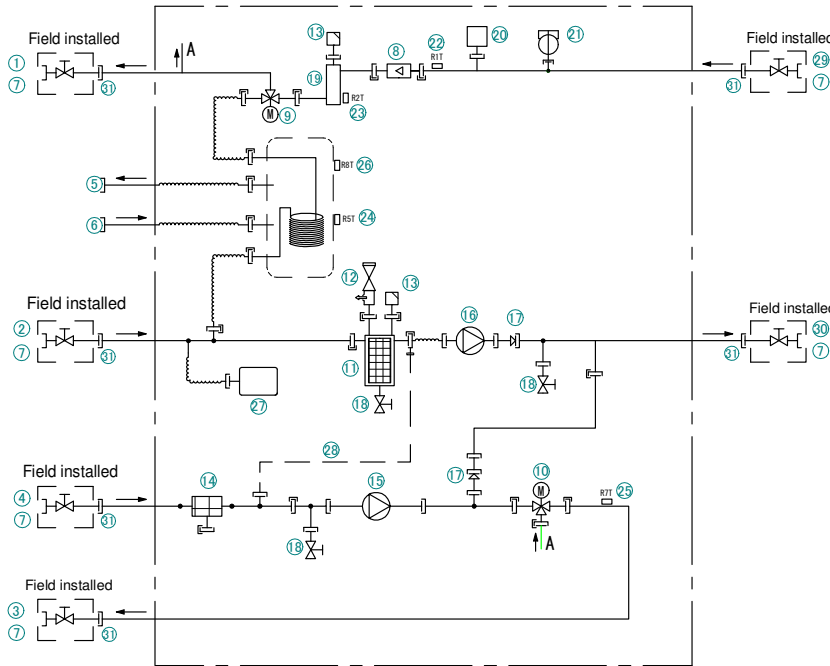

- ① Space heating - water OUT (additional/direct zone)
- ② Space heating - water IN (additional/direct zone)
- ③ Space heating - water OUT (main/mixed zone)
- ④ Space heating - water IN (main/mixed zone)
- ⑤ Domestic hot water: hot water out ·3/4"·
- ⑥ Domestic hot water: cold water in ·3/4"·
- ⑦ Shut-off valve ·1"· (male-female)
- ⑧ Flow sensor
- ⑨ 3-way valve (space heating/domestic hot water)
- ⑩ 3-way valve (mixing valve for the main/mixed zone)
- ⑪ Magnetic filter / dirt separator
- ⑫ Safety valve
- ⑬ Air purge
- ⑭ Water filter (main/mixed zone)
- ⑮ Pump (main/mixed zone)
- ⑯ Pump (additional/direct zone)
- ⑰ Check valve
- ⑱ Drain valve
- ⑲ Backup heater
- ⑳ Space heating water pressure sensor
- ㉑ Flow switch
- ㉒ R1T - Inlet water thermistor
- ㉓ R2T - Outlet water backup heater thermistor
- ㉔ R5T - Tank thermistor
- ㉕ R7T - Water outlet thermistor (main/mixed zone)
- ㉖ R8T - Tank thermistor
- ㉗ Expansion vessel
- ㉘ Capillary tube
- Field piping connections
- ㉙ Water in connection ·1"·
- ㉚ Water out connection ·1"·
- ㉛ Screw connection ·1"·

Screw connection	Brazed connection
Quick coupling	Flare connection

3D120612B

9 Wiring diagrams

9 - 1 Notes & Legend

ETVZ12E6V / ETVZ12E9W

NOTES to go through before starting the unit

- X1M : Main terminal
 - X2M : Field wiring terminal for AC
 - X5M : Field wiring terminal for DC
 - X6M : BUH Power supply terminal
 - X10M : Smartgrid terminal
 - : Earth wiring
 - - - : Field supply
 - ① : Several wiring possibilities
- : Option

: Wiring depending on model

: Not mounted in switch box

: PCB

NOTES

- Connection point of the power supply for the BUH should be foreseen outside the unit.

- Backup heater power supply

 - 6T1 (3~, 230V, 6kW)
 - 6V3 (1N~, 230V, 6kW)
 - 6WN/9WN (3N~, 400V, 6/9kW)

User installed options:

 - Remote user interface
 - Ext. indoor thermistor
 - Ext. outdoor thermistor
 - Digital I/O PCB
 - Demand PCB
 - Safety thermostat
 - Smartgrid kit
 - WLAN adapter module
 - WLAN cartridge

Main LWT:

 - ON/OFF thermostat (wired)
 - ON/OFF thermostat (wireless)
 - Ext. thermistor
 - Heat pump convactor

Add LWT:

 - ON/OFF thermostat (wired)
 - ON/OFF thermostat (wireless)
 - Ext. thermistor
 - Heat pump convactor

POSITION IN SWITCH BOX

LEGEND

Part n°	Description
A1P	main PCB
A2P	* ON/OFF thermostat (PC=power circuit)
A3P	* heat pump convactor
A4P	* digital I/O PCB
ASP	bizone PCB
AGP	current loop PCB
A8P	* demand PCB
A9P	status indicator
A11P	MMI main PCB
A14P	* user interface PCB
A15P	* receiver PCB (wireless ON/OFF thermostat)
A20P	* WLAN adapter module
B2L	flow sensor
B1PW	water pressure sensor
CN* (A4P)	* connector
DS1 (A5P)	dipswitch
DS1 (A8P)	* dipswitch
E1H	backup heater element (1 kW)
E2H	backup heater element (2 kW)
E*P (A9P)	indication LED
F1B	# overcurrent fuse backup heater
F1T	thermal fuse backup heater
F1U, F2U (A4P)	* fuse 5 A 250 V for digital I/O PCB
F1U, F2U (A5P)	* fuse T 3.15 A 250 V for PCB
FU1 (A1P)	fuse T 5 A 250 V for PCB
K1A, K2A	* high voltage smartgrid relay
K1M, K2M	contactor backup heater
K5M	safety contactor BUH
K6M	relay 3 way valve bypass
K7M	relay 3 way valve flow
K*R (A*P)	relay on PCB
M1P	additional zone pump
M1S	mixing 3 way valve
M2P	# domestic hot water pump
M2S	# 2 way valve for cooling mode

Part n°	Description
M3P	main zone pump
M3S	3 way valve for spaceheating/domestic hot water
P1M	MMI display
PC (A15P)	* power circuit
PHC1 (A4P)	* optocoupler input circuit
Q1L	thermal protector backup heater
Q3L, Q4L	# safety thermostat
Q*DI	# earth leakage circuit breaker
R1H (A2P)	* humidity sensor
R1T (A1P)	outlet water heat exchanger thermistor
R1T (A2P)	* ambient sensor ON/OFF thermostat
R1T (A14P)	* ambient sensor user interface
R2T (A1P)	outlet backup heater thermistor
R2T (A2P)	* external sensor (floor or ambient)
R5T, R8T	domestic hot water thermistor
R6T	* external indoor or outdoor ambient thermistor
R7T	mixed leaving water thermistor
S1L	flow switch
S1S	# preferential kWh rate PS contact
S2S	# electrical meter pulse input 1
S3S	# electrical meter pulse input 2
S4S	# smart grid feed-in
S6S-S9S	* digital power limitation inputs
S10S-S11S	# low voltage smartgrid contact
SS1 (A4P)	* selector switch
SW1~2 (A12P)	turn buttons
SW3~5 (A12P)	push button
TR1	power supply transformer
X6M	# BUH power supply terminal strip
X10M	* smartgrid power supply terminal strip
X*, X*A, J*	connector
X*H*, X*Y	connector
X*M	terminal strip

*: optional #: field supply

4D128377C

9 Wiring diagrams

9 - 2 Control Circuit

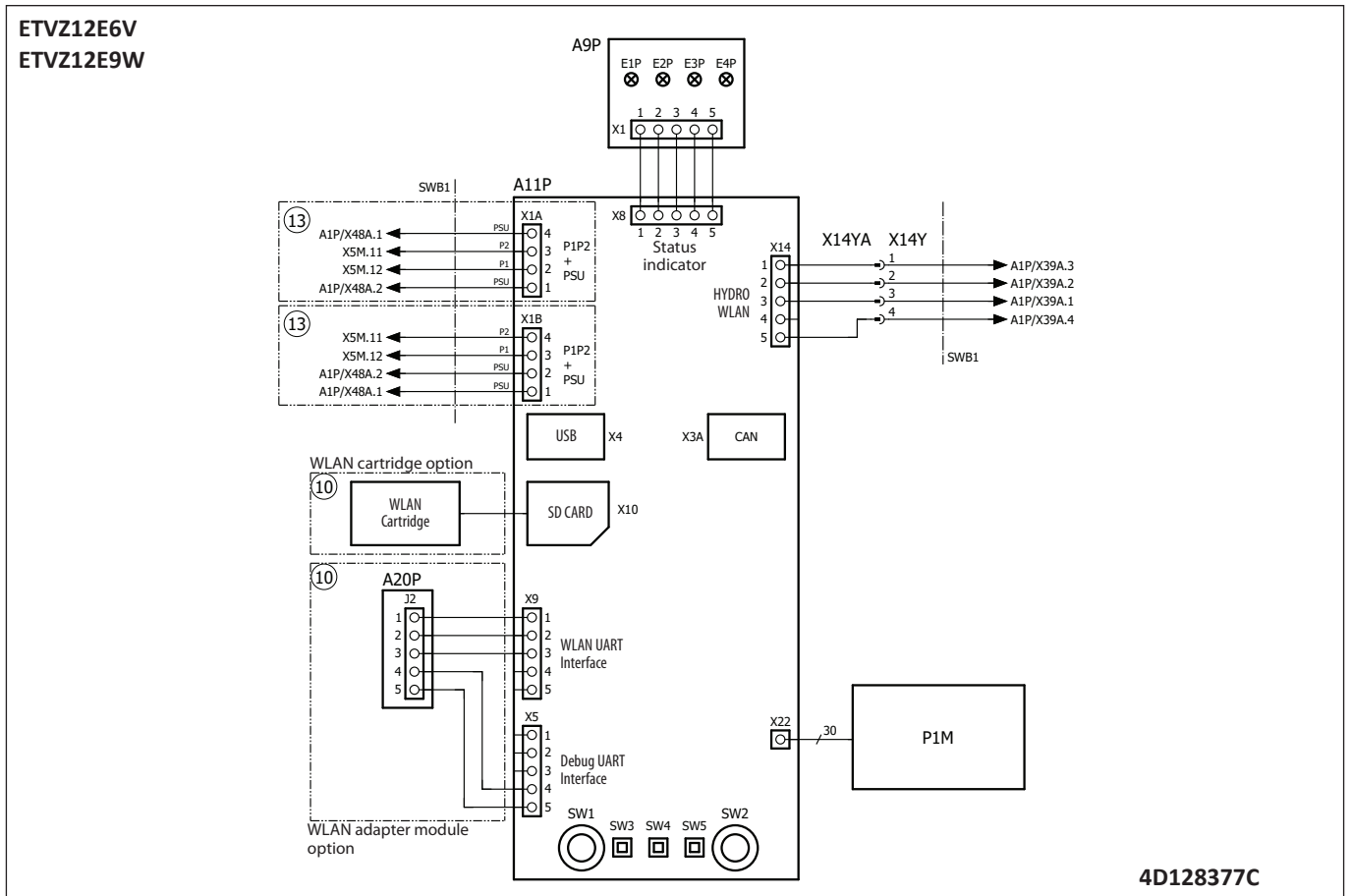

9 Wiring diagrams

9 - 3 Power Supply, Back-up Heater

9

ETVZ12E6V / ETVZ12E9W

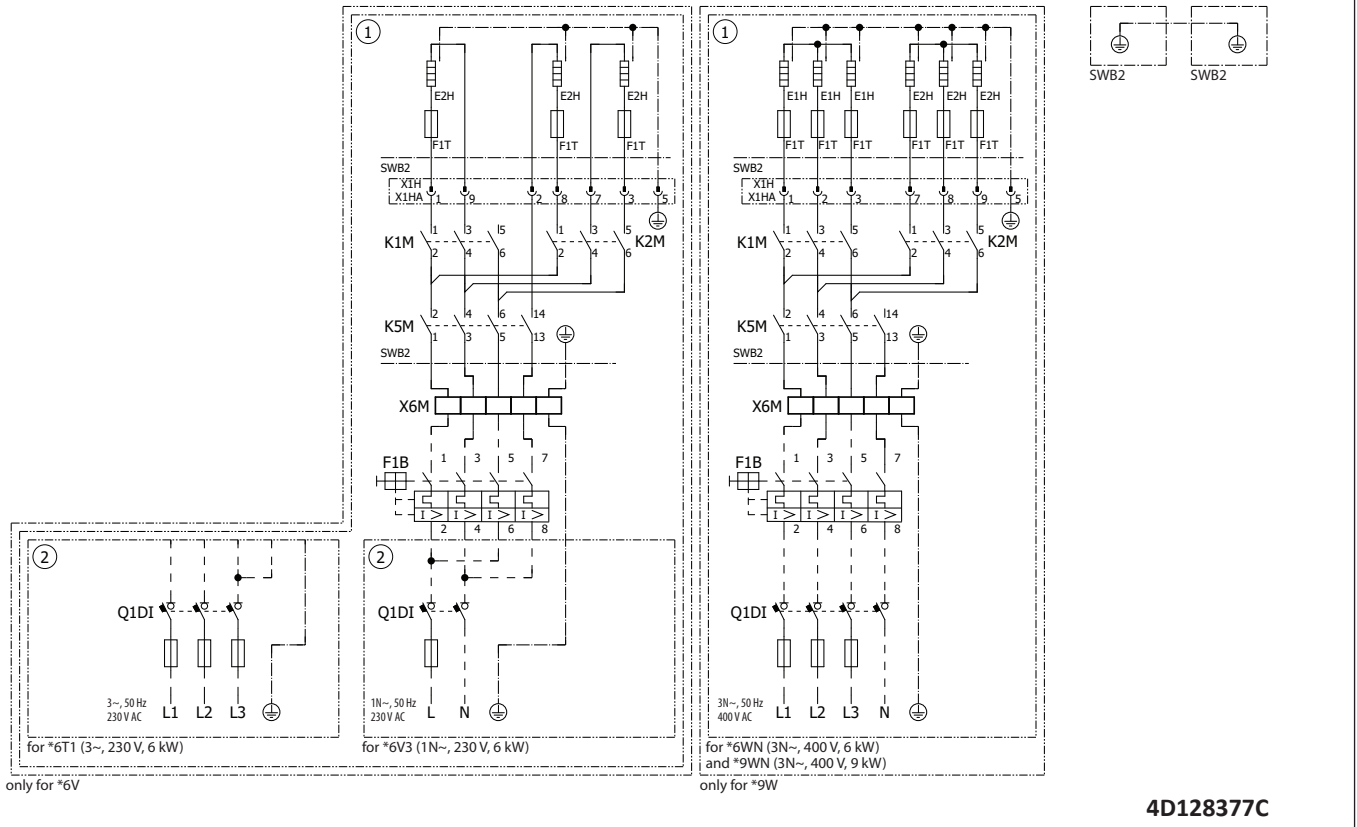

10 External connection diagrams

10 - 1 External Connection Diagrams

ETVZ12E6V
ETVZ12E9W

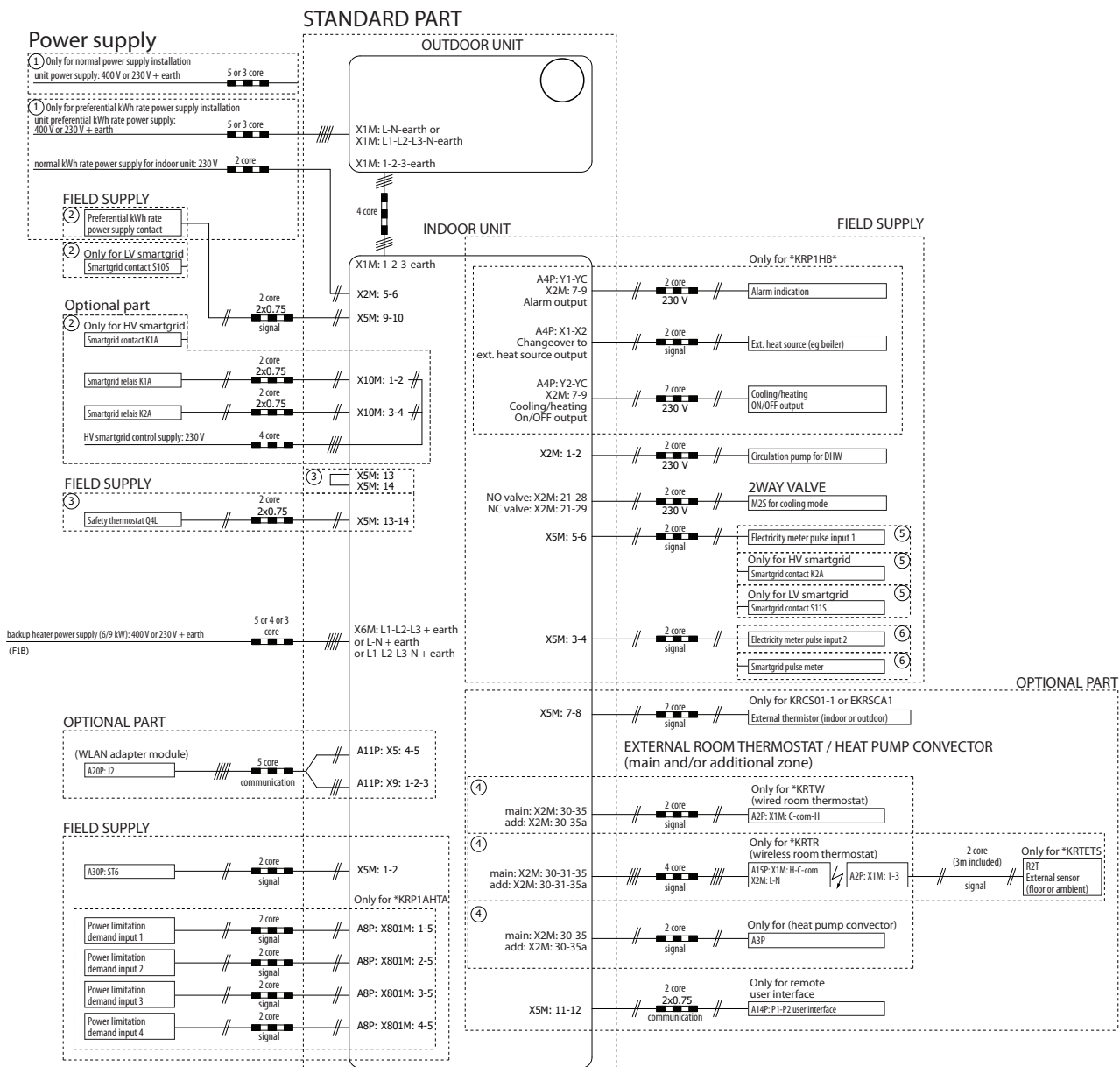

NOTE

- In case of signal cable: keep minimum distance to power cables > 5 cm

4D133017B

11 Installation

11 - 1 Installation Method

11

ETVZ12E6V / ETVZ16E6V
ETVZ12E9W / ETVZ16E9W

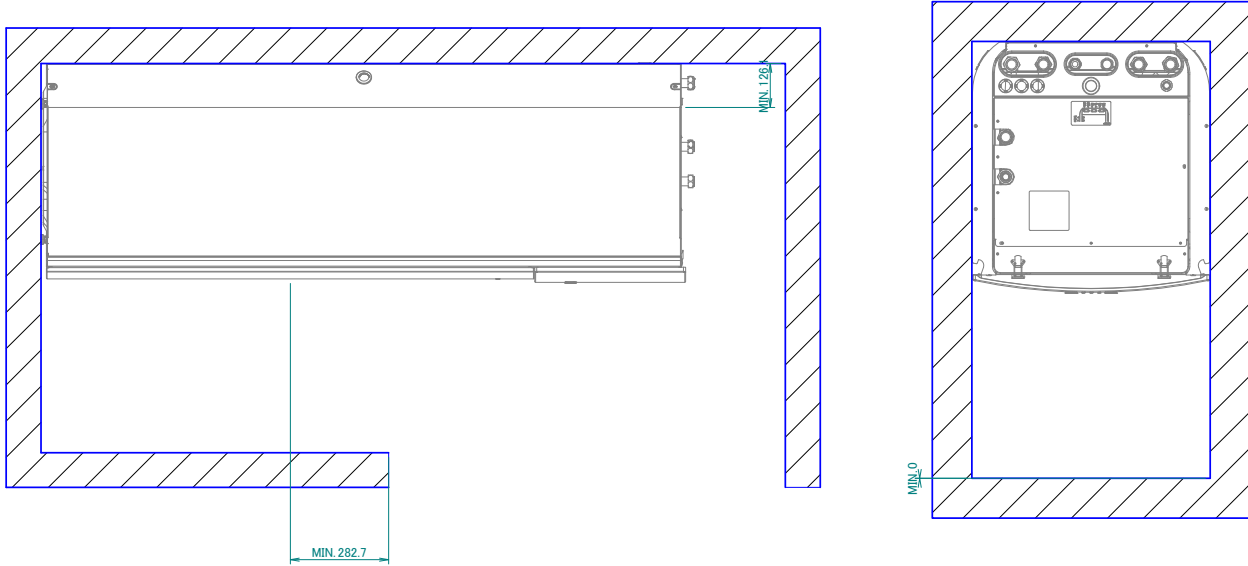

3D121005A

12 Operation range

12 - 1 Operation Range

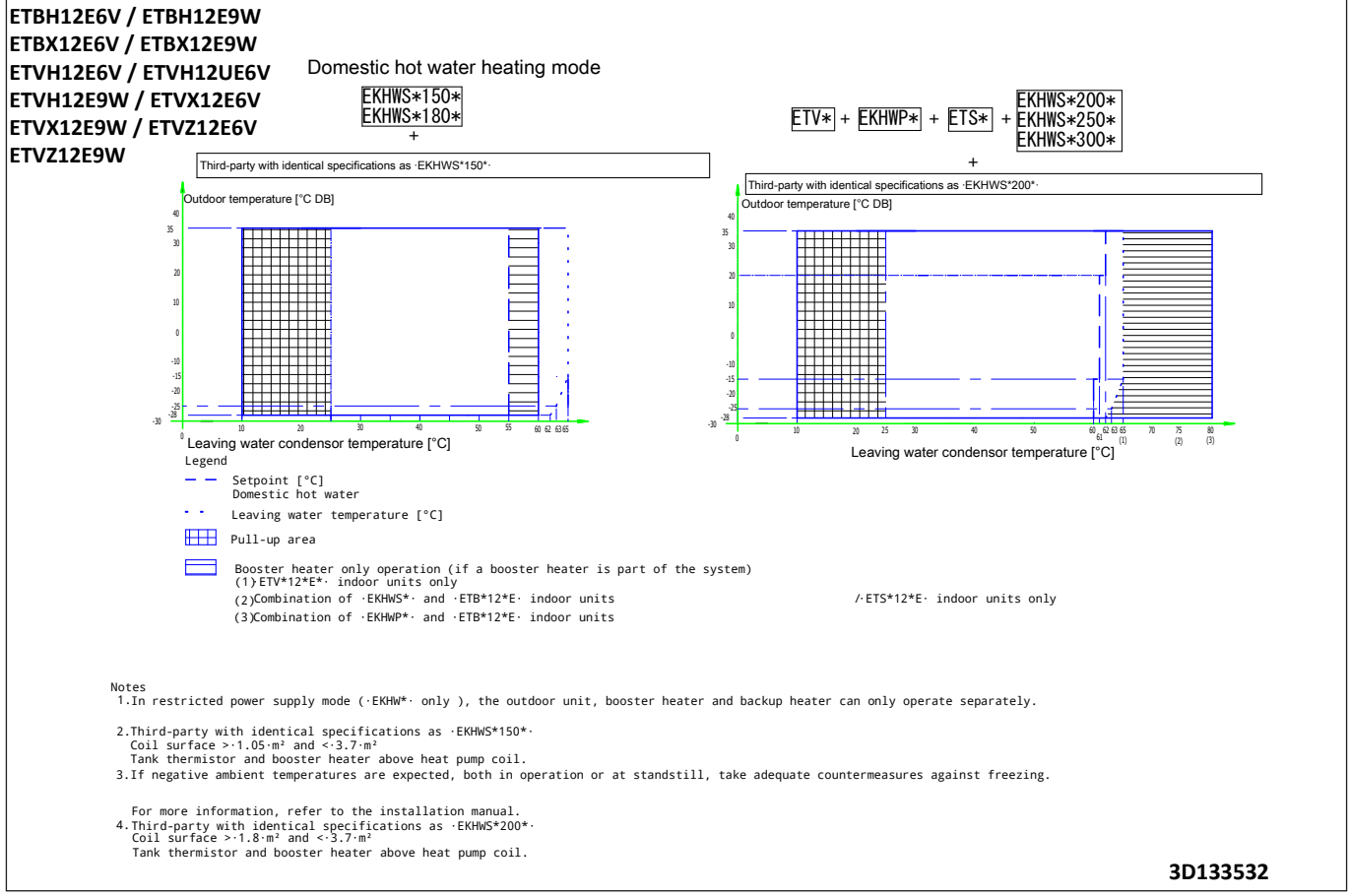
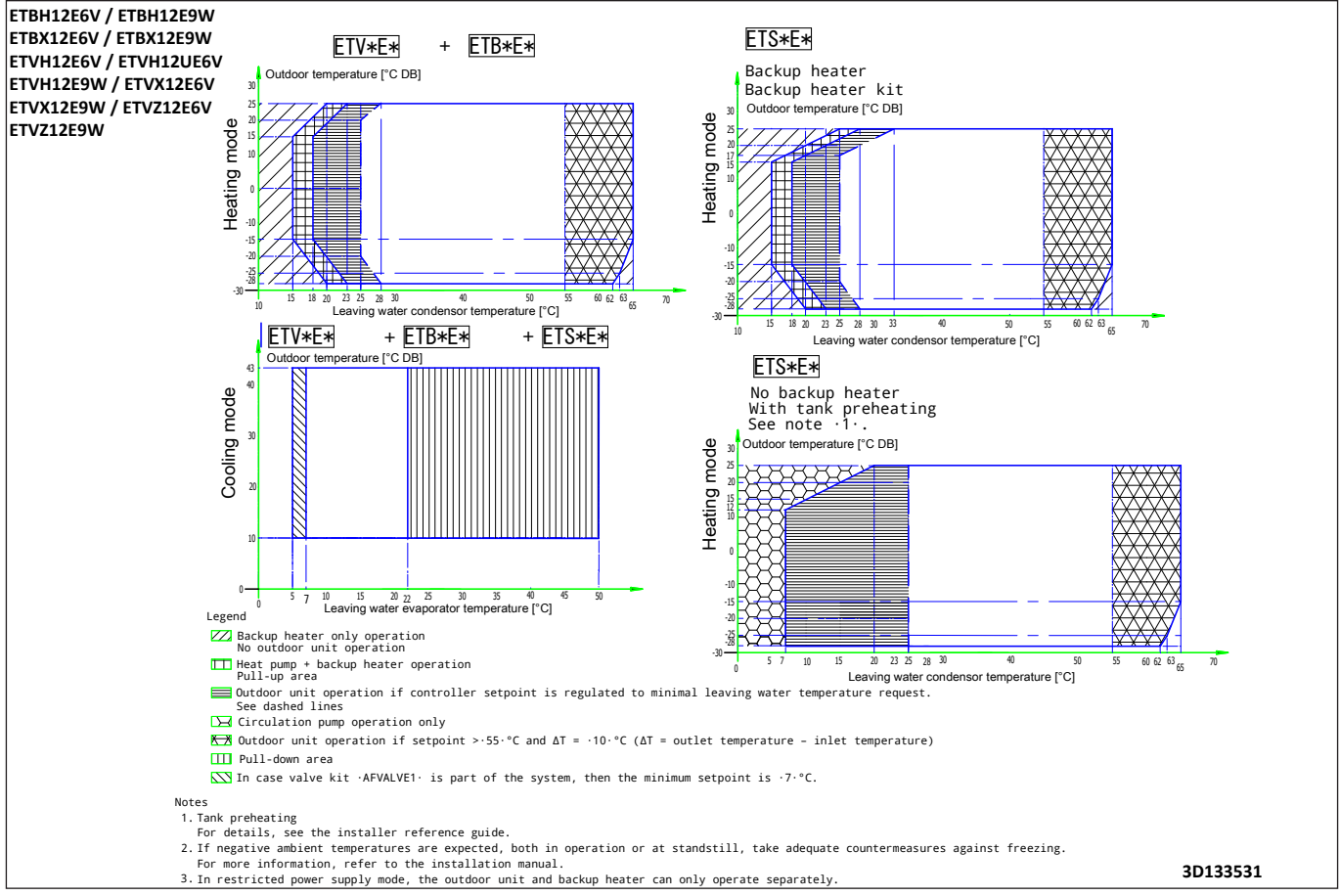

13 Hydraulic performance

13 - 1 Static Pressure Drop Unit

13

ETVZ12E6V
ETVZ12E9W

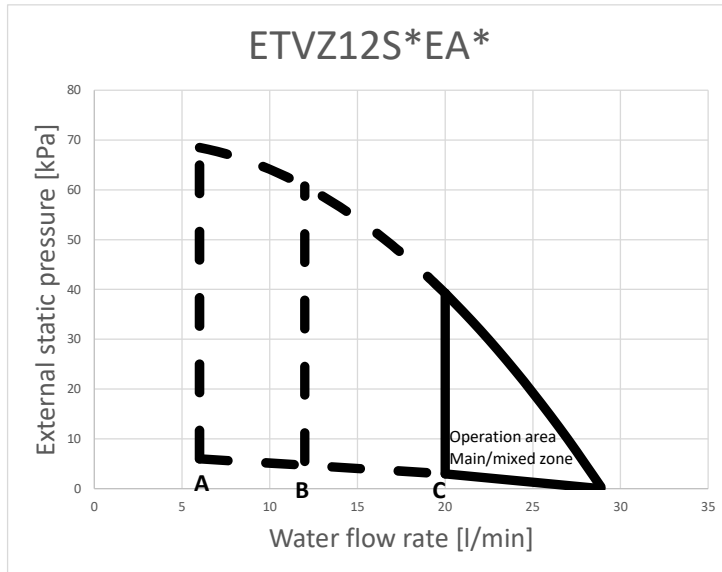

- A Minimum water flow rate during normal operation
- B Minimum water flow rate during backup heater operation
- C Minimum water flow rate during defrost operation

Operation area is extended to lower flow rates only in case the unit operates with heat pump only.
(Not in startup, no BUH operation, no defrost operation.)

See dashed lines

Notes

1. Selecting a flow outside the operating area can damage the unit or cause the unit to malfunction.
See also the minimum and maximum allowed water flow range in the technical specifications.
2. Water quality must be according to EU directive 98/83 EC.

4D133486A

ETVZ12E6V
ETVZ12E9W

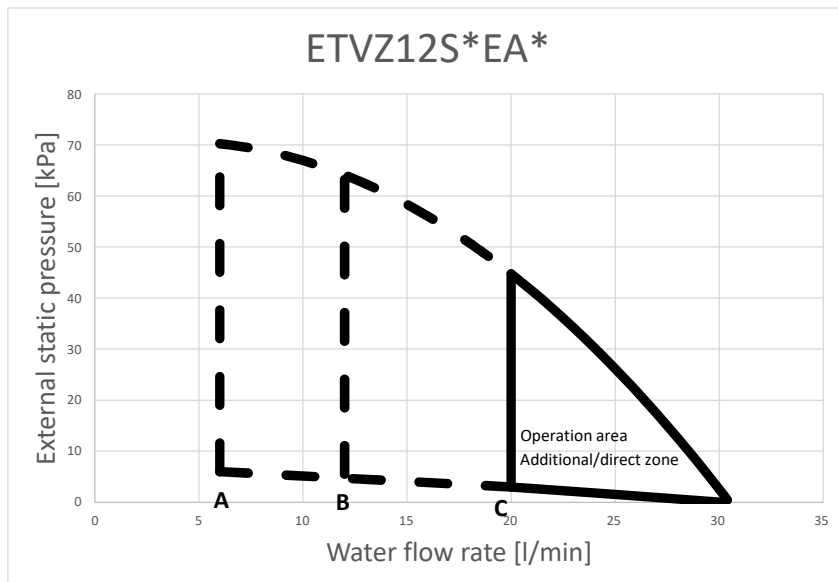

- A Minimum water flow rate during normal operation
- B Minimum water flow rate during backup heater operation
- C Minimum water flow rate during defrost operation

Operation area is extended to lower flow rates only in case the unit operates with heat pump only.
(Not in startup, no BUH operation, no defrost operation.)

See dashed lines

Notes

1. Selecting a flow outside the operating area can damage the unit or cause the unit to malfunction.
See also the minimum and maximum allowed water flow range in the technical specifications.
2. Water quality must be according to EU directive 98/83 EC.

4D133486A

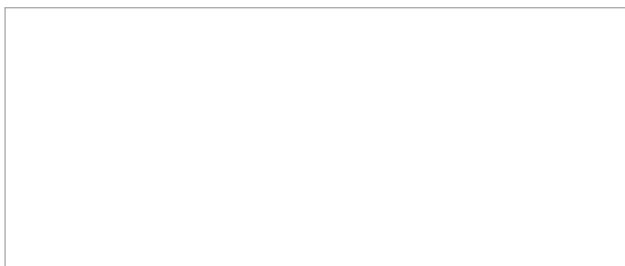

EEEDEN22



02/2022



The present publication is drawn up by way of information only and does not constitute an offer binding upon Daikin Europe N.V. / Daikin Central Europe HandelsGmbH. Daikin Europe N.V. / Daikin Central Europe HandelsGmbH have compiled the content of this publication to the best of their knowledge. No express or implied warranty is given for the completeness, accuracy, reliability or fitness for particular purpose of its content and the products and services presented therein. Specifications are subject to change without prior notice. Daikin Europe N.V. / Daikin Central Europe HandelsGmbH explicitly rejects any liability for any direct or indirect damage, in the broadest sense, arising from or related to the use and/or interpretation of this publication. All content is copyrighted by Daikin Europe N.V.