



◀ **Radiator**

Grid 990 ↑ x 500 ↔ ZX,
radiator colour: Metallic Black,
radiator code: WGGRD099050 KMBCZX

Valves and accessories

Integrated thermostatic valve,
RAL 9005 Gloss
VAZ thermostatic head, Midnight
Hanger ZIP V 30, Midnight
Simple shelf, Oak

251 COLOURS



GRID





AVAILABLE SIZES

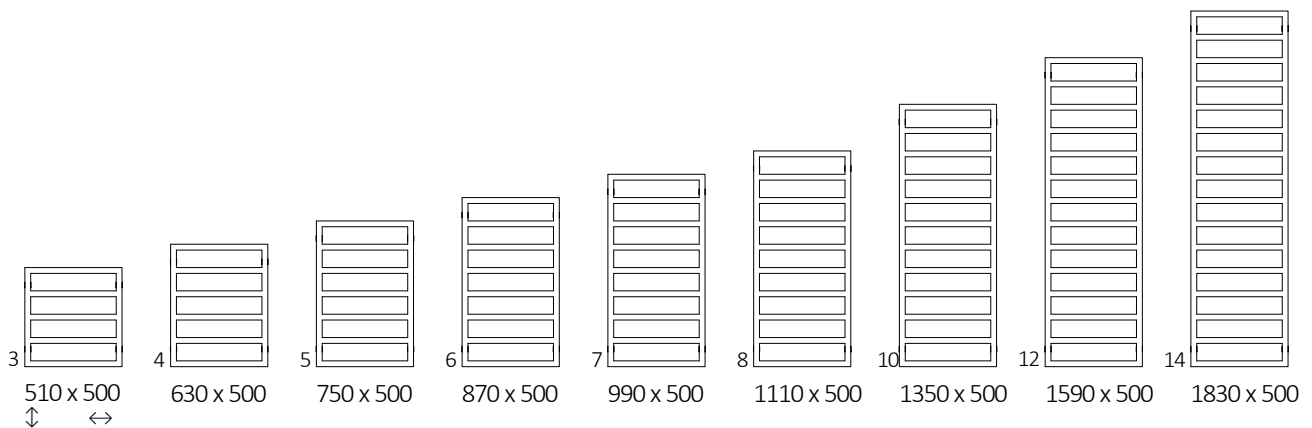

1. RADIATOR

CENTRAL HEATING / DUAL FUEL

Connections:

A ⇕ 510

A ⇕ 630÷1830





Height A ⇕ [mm]	Width B ⇔ [mm]	Heating power – powder paint			Product code ... Configuration p. 21
		75/65/20°C [W]	55/45/20°C [W]	[W]	
510	500	217	123	200	WGGRD051050
630	500	262	145	300	WGGRD063050
750	500	306	167	300	WGGRD075050
870	500	351	189	400	WGGRD087050
990	500	396	211	400	WGGRD099050
1110	500	440	234	400	WGGRD111050
1350	500	529	271	600	WGGRD135050
1590	500	618	308	600	WGGRD159050
1830	500	707	342	800	WGGRD183050

DIMENSIONS AND TECHNICAL INFORMATION

Working pressure: 1000 kPa

Maximum operating temperature: 95°C

Height A ↕ [mm]	Width B ↔ [mm]	Spacing connection C1 [mm]	Spacing connection C2 [mm]	Spacing connection C3 [mm]	Spacing horizontal fasteners D [mm]	Spacing vertical fasteners E [mm]	Bottom fasteners position F [mm]	Capacity  [dm³]	Weight  [kg]
510	500	50	470	480	470	330	90	2,32	4,28
630	500	50	470	600	470	450	90	2,81	5,19
750	500	50	470	720	470	570	90	3,30	6,09
870	500	50	470	840	470	690	90	3,79	6,99
990	500	50	470	960	470	810	90	4,28	7,88
1110	500	50	470	1080	470	930	90	4,77	8,78
1350	500	50	470	1320	470	1170	90	5,76	10,58
1590	500	50	470	1560	470	1410	90	6,74	12,38
1830	500	50	470	1800	470	1650	90	7,72	14,18



ELECTRIC RADIATOR

Connections:



Height A ↕ [mm]	Width B ↔ [mm]	Heating power – powder paint [W]	Kod produktu ... Kod konfigur. info.s.22
510	500	200	WLGRD051050
630	500	300	WLGRD063050
750	500	300	WLGRD075050
870	500	400	WLGRD087050
990	500	400	WLGRD099050
1110	500	400	WLGRD111050
1350	500	600	WLGRD135050
1590	500	600	WLGRD159050
1830	500	800	WLGRD183050

DIMENSIONS AND TECHNICAL INFORMATION

Height A ↕ [mm]	Width B ↔ [mm]	Spacing horizontal fasteners D [mm]	Spacing vertical fasteners E [mm]	Bottom fasteners position F [mm]	Capacity  [dm³]	Weight  [kg]
510	500	470	480	90	2,32	6,16
630	500	470	600	90	2,81	7,47
750	500	470	720	90	3,30	8,76
870	500	470	840	90	3,79	10,06
990	500	470	960	90	4,28	11,35
1110	500	470	1080	90	4,77	12,64
1350	500	470	1320	90	5,76	15,25
1590	500	470	1560	90	6,74	17,84
1830	500	470	1800	90	7,72	20,43

TECHNICAL DRAWING

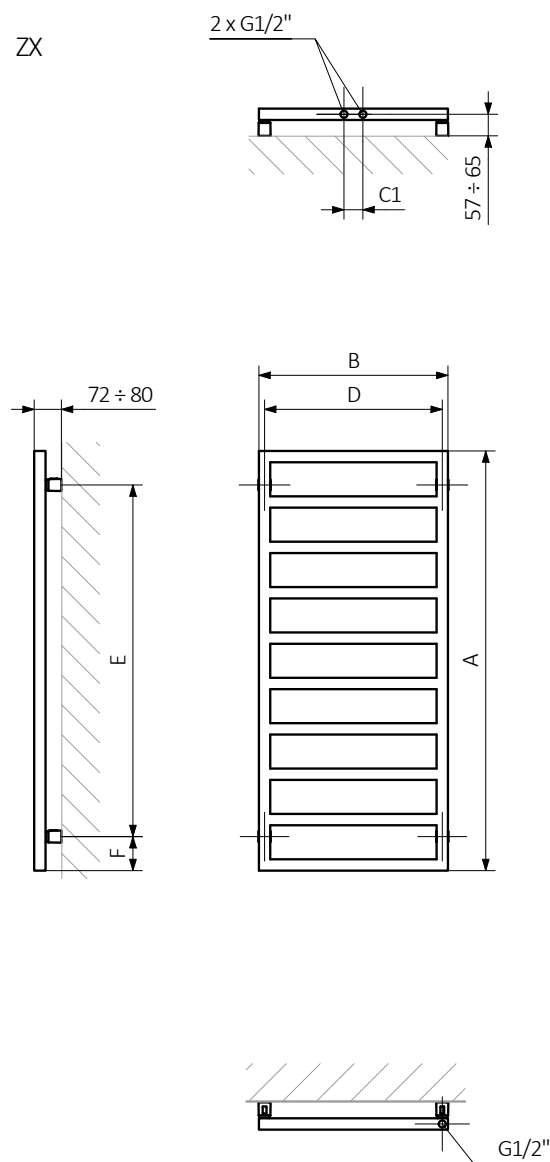

A – Height B – Width C1-C5 – Distance between pipe centres D – Horizontal distance between mounting bracket centres E – Vertical distance between mounting brackets F – Distance between a mounting bracket and the bottom of the radiator

Pipe:

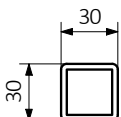

TECHNICAL DRAWING

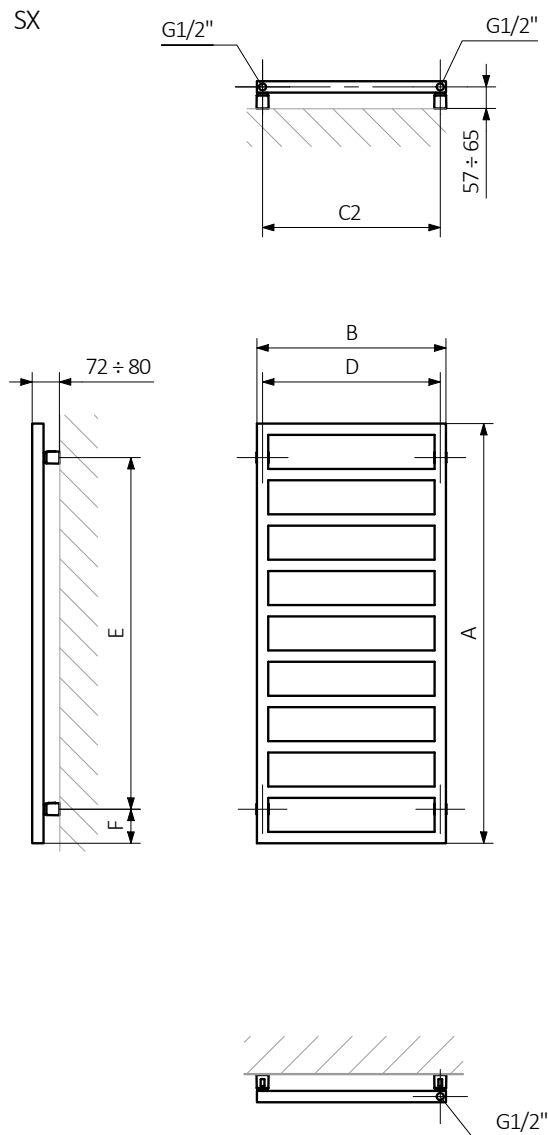

A – Height B – Width C1-C5 – Distance between pipe centres D – Horizontal distance between mounting bracket centres E – Vertical distance between mounting brackets F – Distance between a mounting bracket and the bottom of the radiator

Pipe:

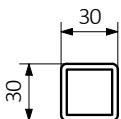

TECHNICAL DRAWING

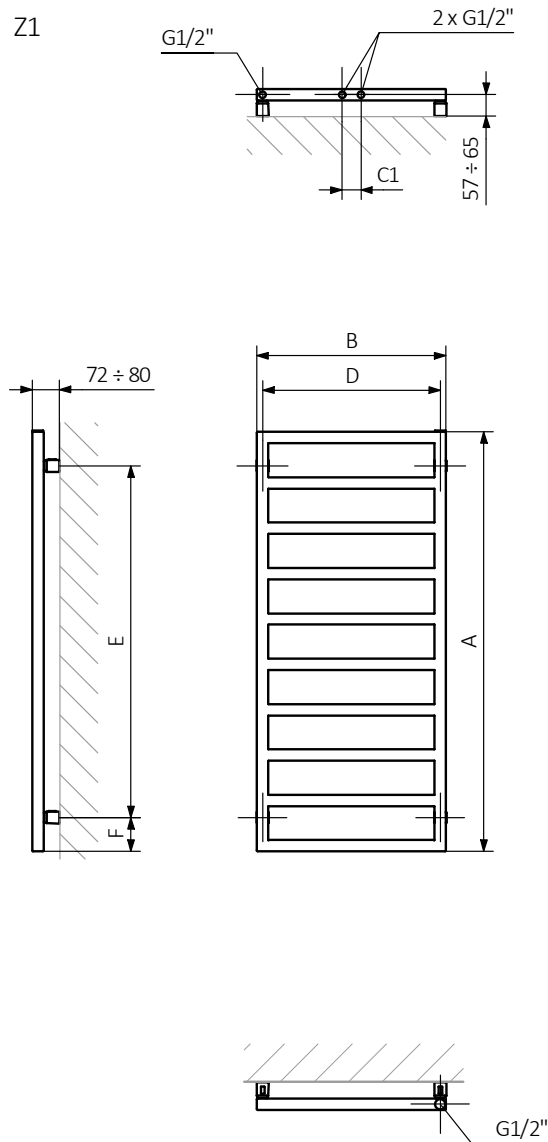

A – Height B – Width C1-C5 – Distance between pipe centres D – Horizontal distance between mounting bracket centres E – Vertical distance between mounting brackets F – Distance between a mounting bracket and the bottom of the radiator

Pipe:

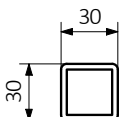

TECHNICAL DRAWING

Z8

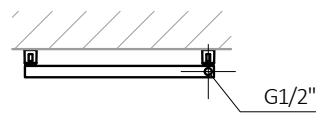
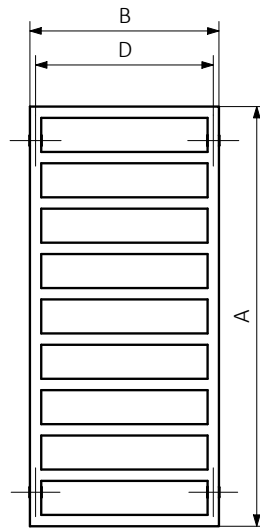
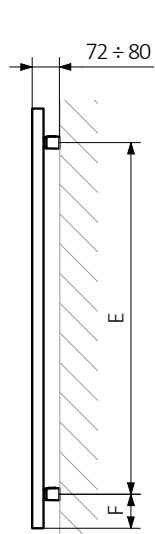
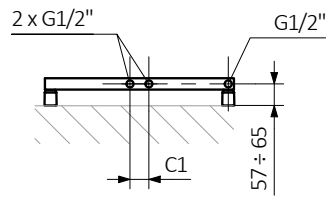

A – Height B – Width C1-C5 – Distance between pipe centres D – Horizontal distance between mounting bracket centres E – Vertical distance between mounting brackets F – Distance between a mounting bracket and the bottom of the radiator

Pipe:

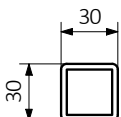

TECHNICAL DRAWING

PX

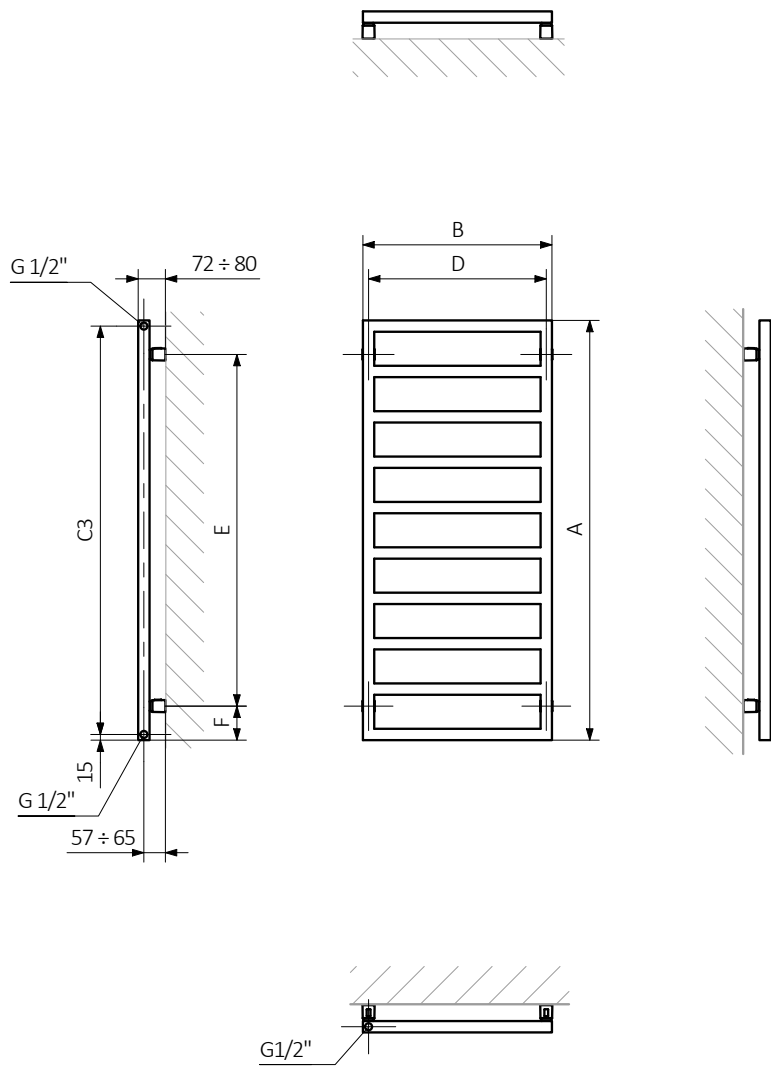

A – Height B – Width C1-C5 – Distance between pipe centres D – Horizontal distance between mounting bracket centres E – Vertical distance between mounting brackets F – Distance between a mounting bracket and the bottom of the radiator

Pipe:

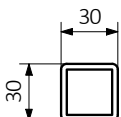

TECHNICAL DRAWING

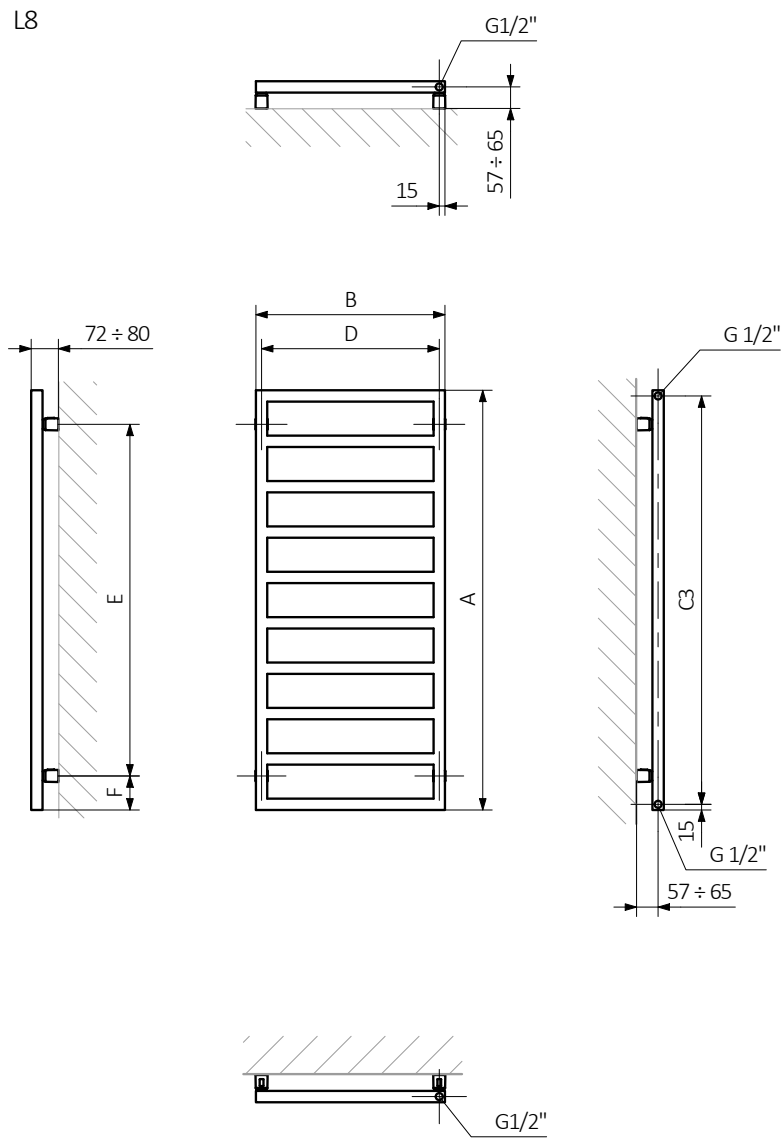

A – Height B – Width C1-C5 – Distance between pipe centres D – Horizontal distance between mounting bracket centres E – Vertical distance between mounting brackets F – Distance between a mounting bracket and the bottom of the radiator

Pipe:

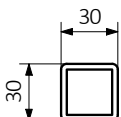

TECHNICAL DRAWING

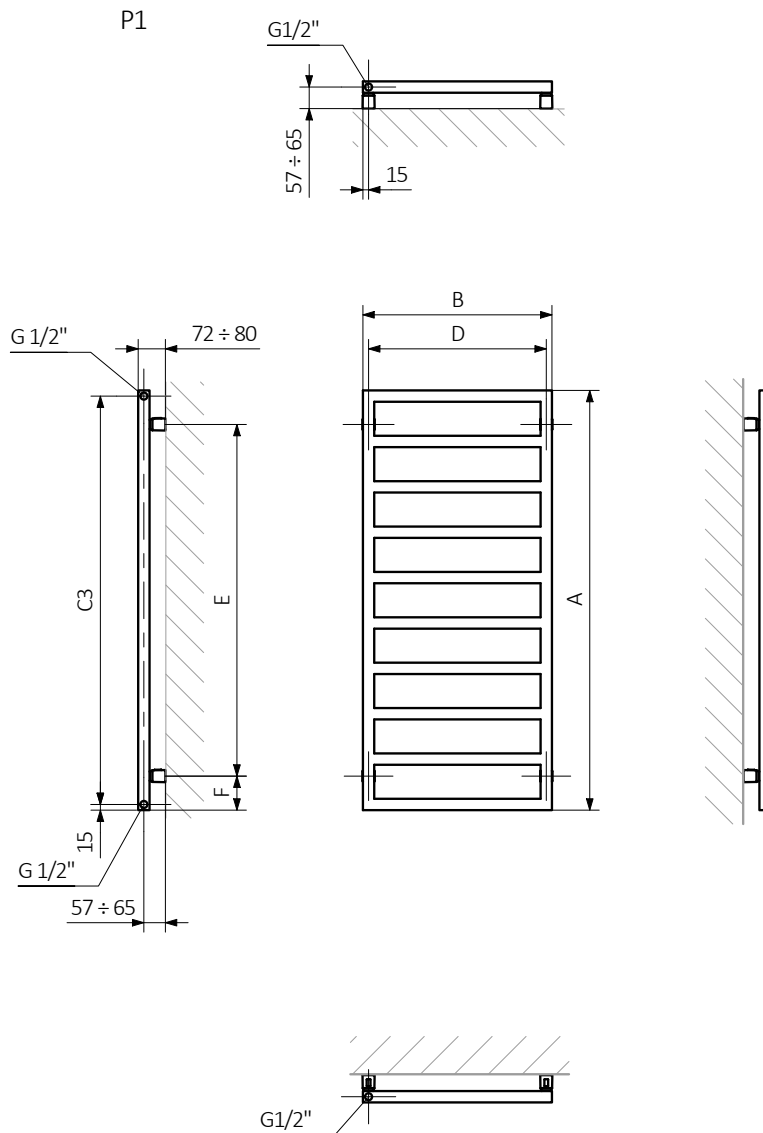

A – Height B – Width C1-C5 – Distance between pipe centres D – Horizontal distance between mounting bracket centres E – Vertical distance between mounting brackets F – Distance between a mounting bracket and the bottom of the radiator

Pipe:

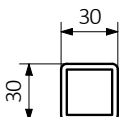

TECHNICAL DRAWING

LX

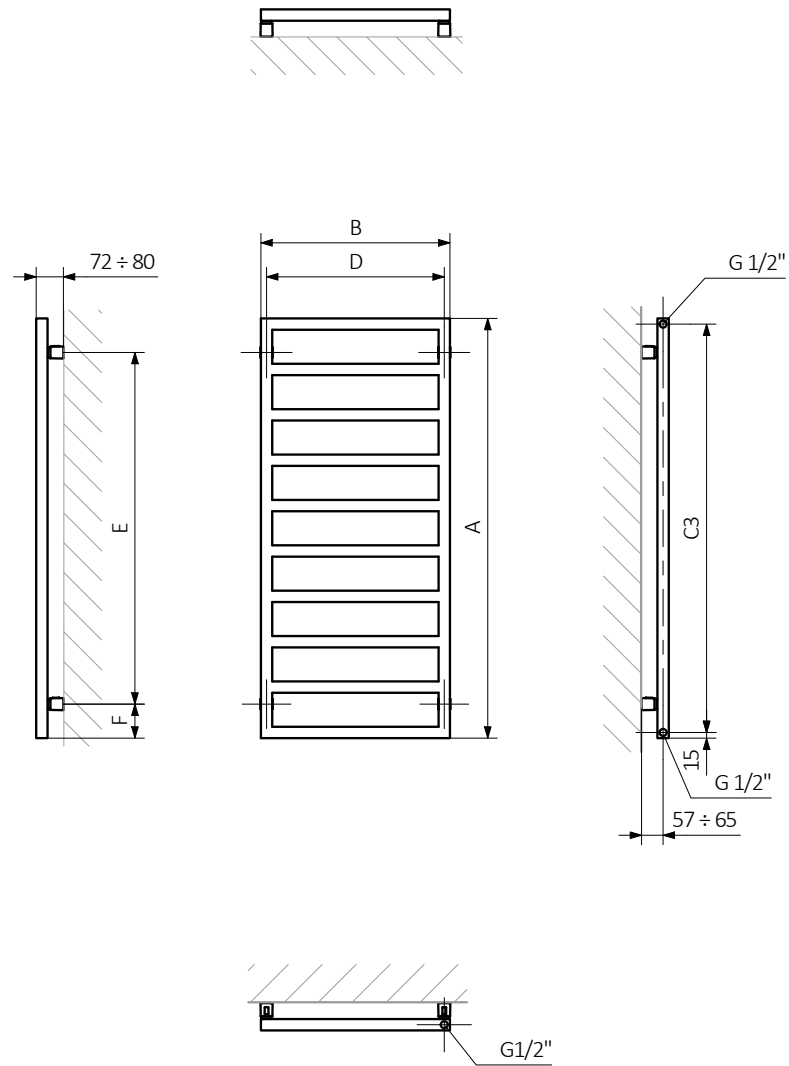

A – Height B – Width C1-C5 – Distance between pipe centres D – Horizontal distance between mounting bracket centres E – Vertical distance between mounting brackets F – Distance between a mounting bracket and the bottom of the radiator

Pipe:

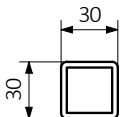

TECHNICAL DRAWING

58

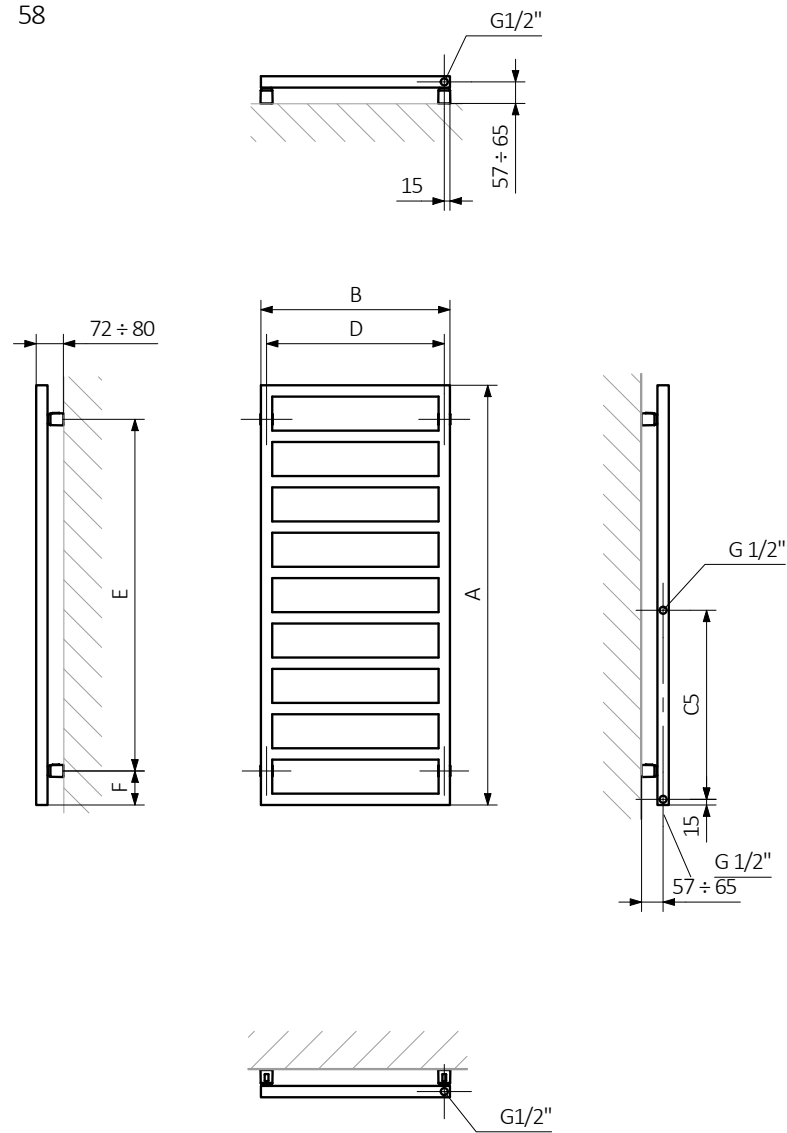

A – Height B – Width C1-C5 – Distance between pipe centres D – Horizontal distance between mounting bracket centres E – Vertical distance between mounting brackets F – Distance between a mounting bracket and the bottom of the radiator

Pipe:

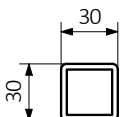

TECHNICAL DRAWING

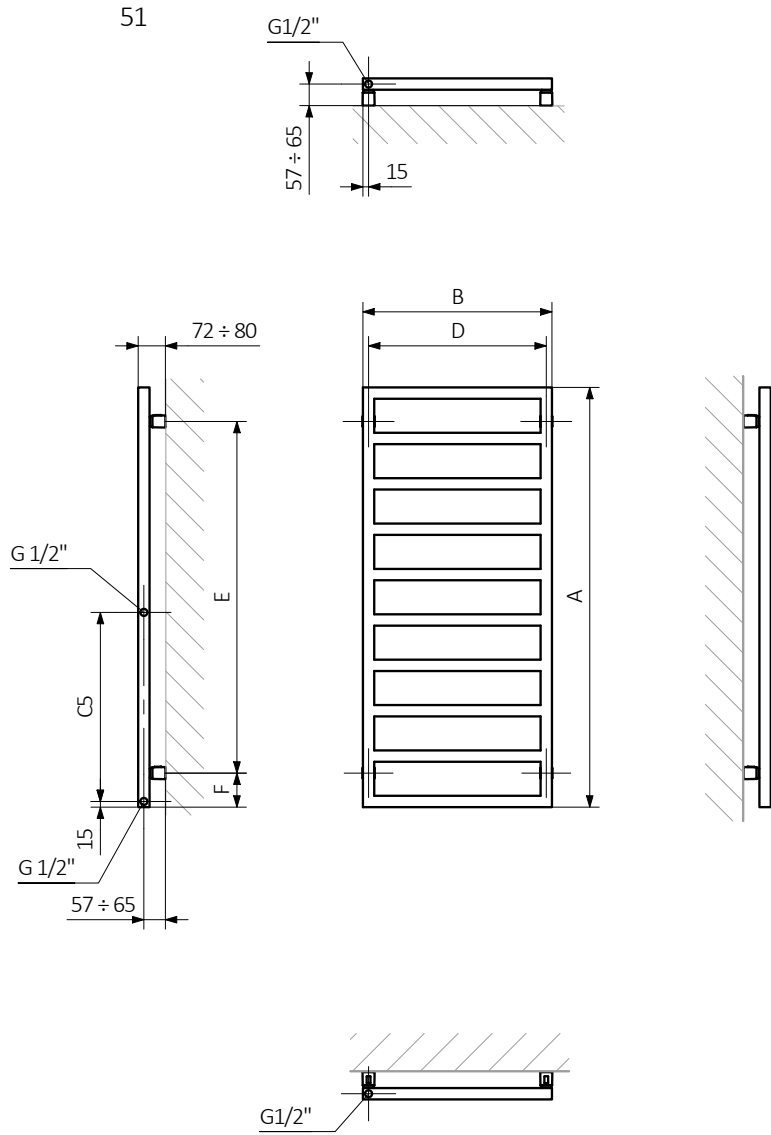

A – Height B – Width C1-C5 – Distance between pipe centres D – Horizontal distance between mounting bracket centres E – Vertical distance between mounting brackets F – Distance between a mounting bracket and the bottom of the radiator

Pipe:

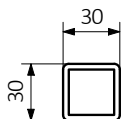

TECHNICAL DRAWING

5P

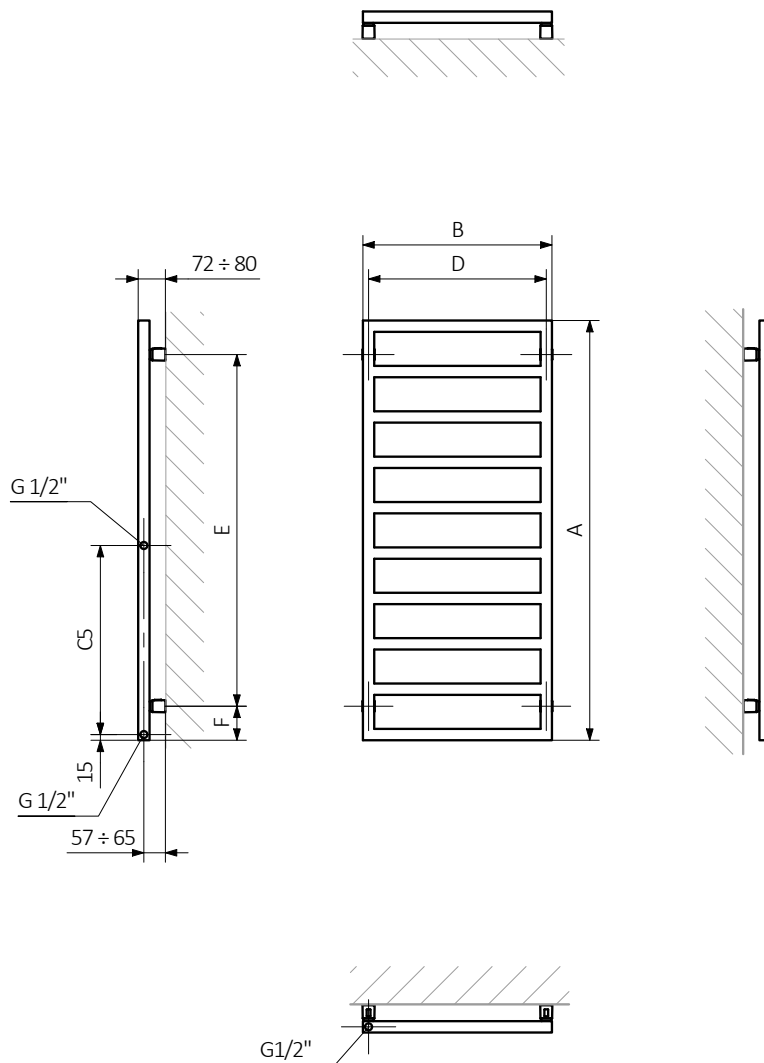

A – Height B – Width C1-C5 – Distance between pipe centres D – Horizontal distance between mounting bracket centres E – Vertical distance between mounting brackets F – Distance between a mounting bracket and the bottom of the radiator

Pipe:

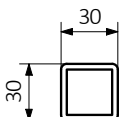

TECHNICAL DRAWING

5L

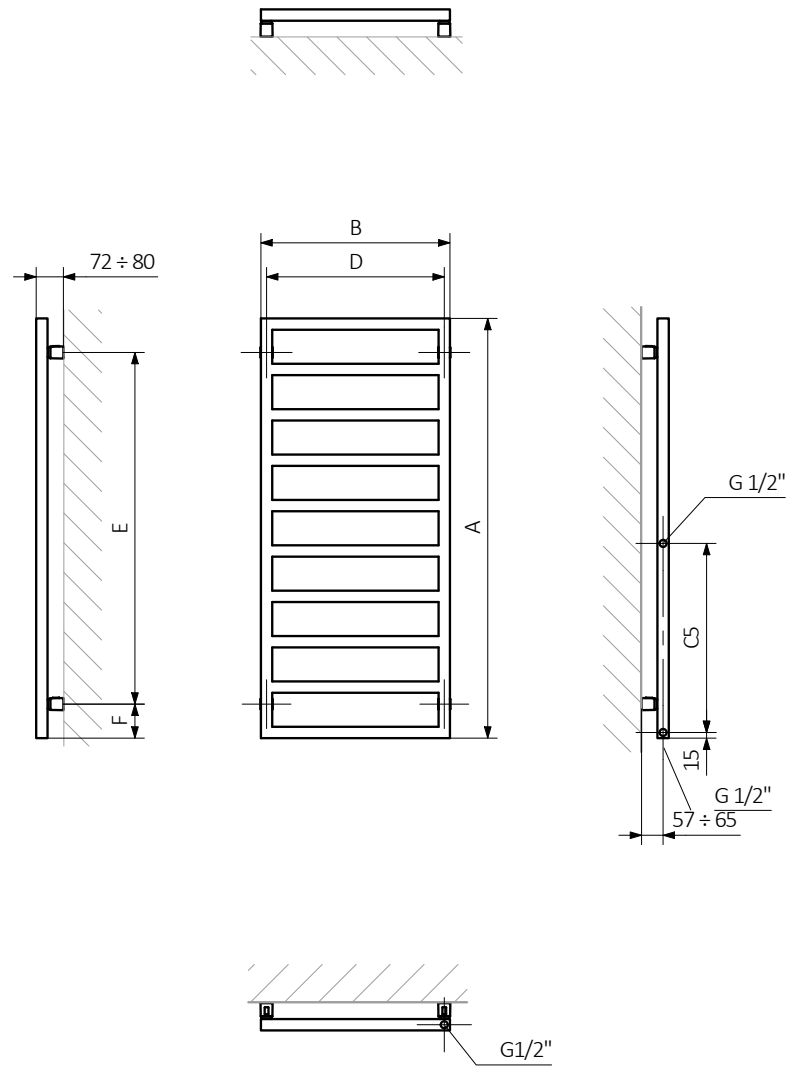

A – Height B – Width C1-C5 – Distance between pipe centres D – Horizontal distance between mounting bracket centres E – Vertical distance between mounting brackets F – Distance between a mounting bracket and the bottom of the radiator

Pipe:

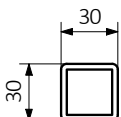

TECHNICAL DRAWING

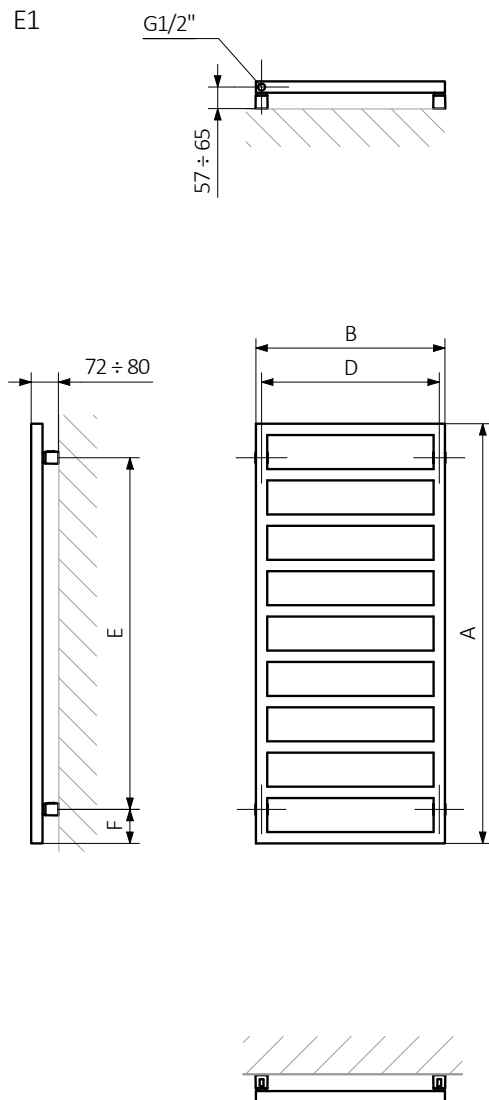

A – Height B – Width C1-C5 – Distance between pipe centres D – Horizontal distance between mounting bracket centres E – Vertical distance between mounting brackets F – Distance between a mounting bracket and the bottom of the radiator

Pipe:

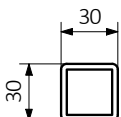

TECHNICAL DRAWING

E8

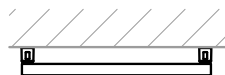
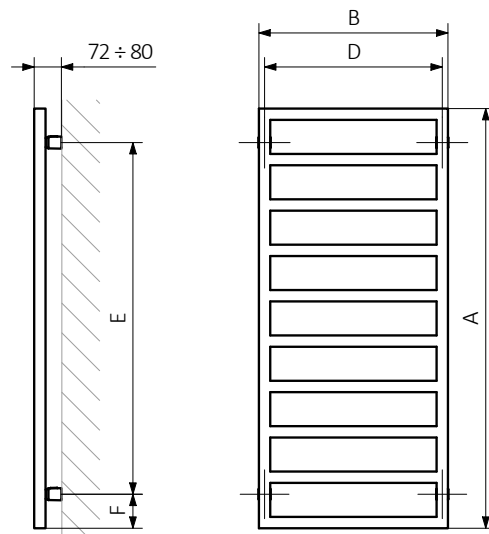
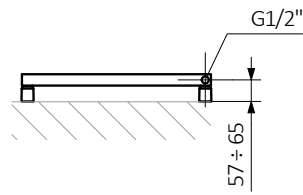

A – Height B – Width C1-C5 – Distance between pipe centres D – Horizontal distance between mounting bracket centres E – Vertical distance between mounting brackets F – Distance between a mounting bracket and the bottom of the radiator

Pipe:

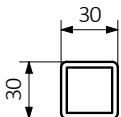

Shelf Simple

AVAILABLE MATERIAL:



Size [mm]	B [mm]	Material	Product code and configuration
500	440	Beech	WRPSIM050 KBUK
500	440	Oak	WRPSIM050 KDAB
500	440	Teak	WRPSIM050 KTEK

Simple Hanger

COLOUR OPTIONS:

RAL and Terma special colours only



Size	Product code
500 mm	WRWSIM004

ZIP V30 Hanger

COLOUR OPTIONS:



Size	Colour	Product code and configuration
30 mm	Chrom	WRWZIP012 KCRO
30 mm	Bottle Green	WRWZIP012 KBGR
30 mm	Champagne	WRWZIP012 KCPG
30 mm	Red Wine	WRWZIP012 KRWE
30 mm	Midnight	WRWZIP012 KMDN
30 mm	Pers	WRWZIP012 KPER
30 mm	Raw Metal	WRWZIP012 KRAW
30 mm	Brushed Brass	WRWZIP012 KBBS
30 mm	Old Bronze	WRWZIP012 KOBZ
30 mm	Metal Alive	WRWZIP012 KMAV
30 mm	Brass	WRWZIP012 KBRA
30 mm	True Copper Bright	WRWZIP012 KTCG
30 mm	Silver	WRWZIP012 KSVR

CONFIGURATION CODE FOR A TOWEL RAIL OR RADIATOR ("WG" PRODUCT GROUP)

Product codes can be found in the product tables in both the catalogue and the price list. They provide basic information about the product and the configuration code contains information that complements the specification. When placing an order, the product codes should contain the fully completed configuration part. Part of the configuration code should be placed after the main product code as shown in the example below:

CODE DETAILS:

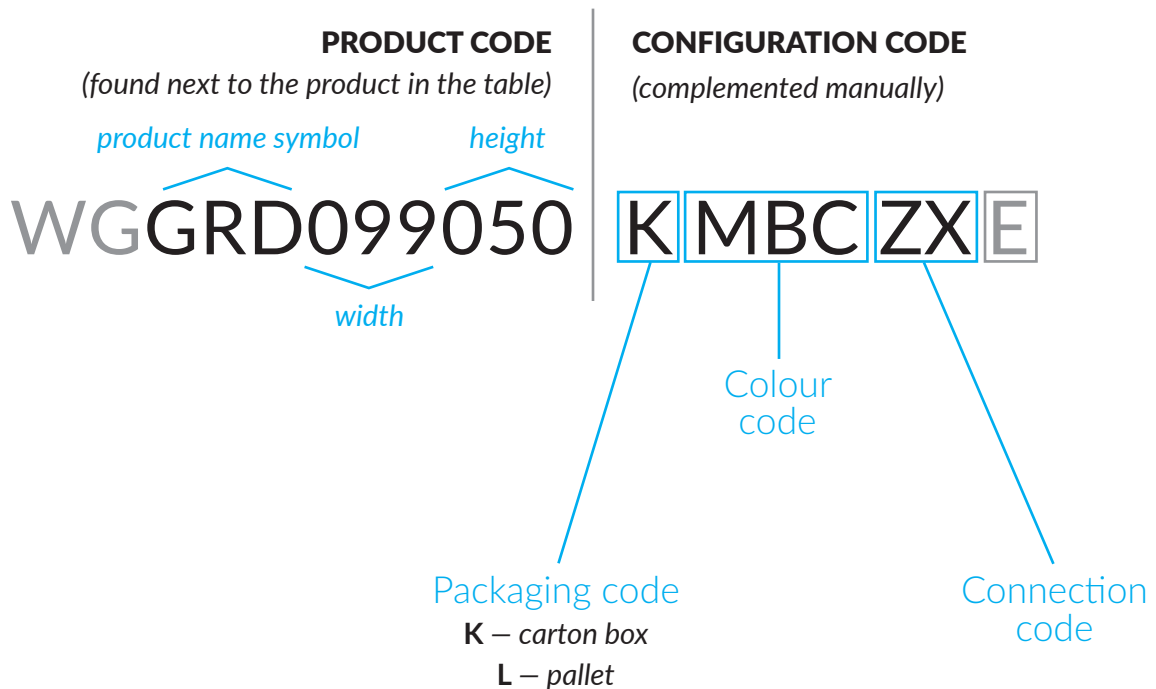

WG – water or dual fuel, central heating towel rail or radiator

E – the epoxy primer (additional coating increases the corrosion resistance of the product).

A CONFIGURATION CODE FOR AN ELECTRIC TOWEL RAIL OR RADIATOR FILLED WITH OIL AND FITTED WITH A HEATING ELEMENT (PRODUCT GROUP "WL")

Product codes can be found in the product tables in both the catalogue and the price list. They provide basic information about the product, and the configuration code contains information that complements the specification. When placing an order, the product codes should contain the fully completed configuration part. Part of the configuration code should be placed after the main product code as shown in the example below:

CODE DETAILS:

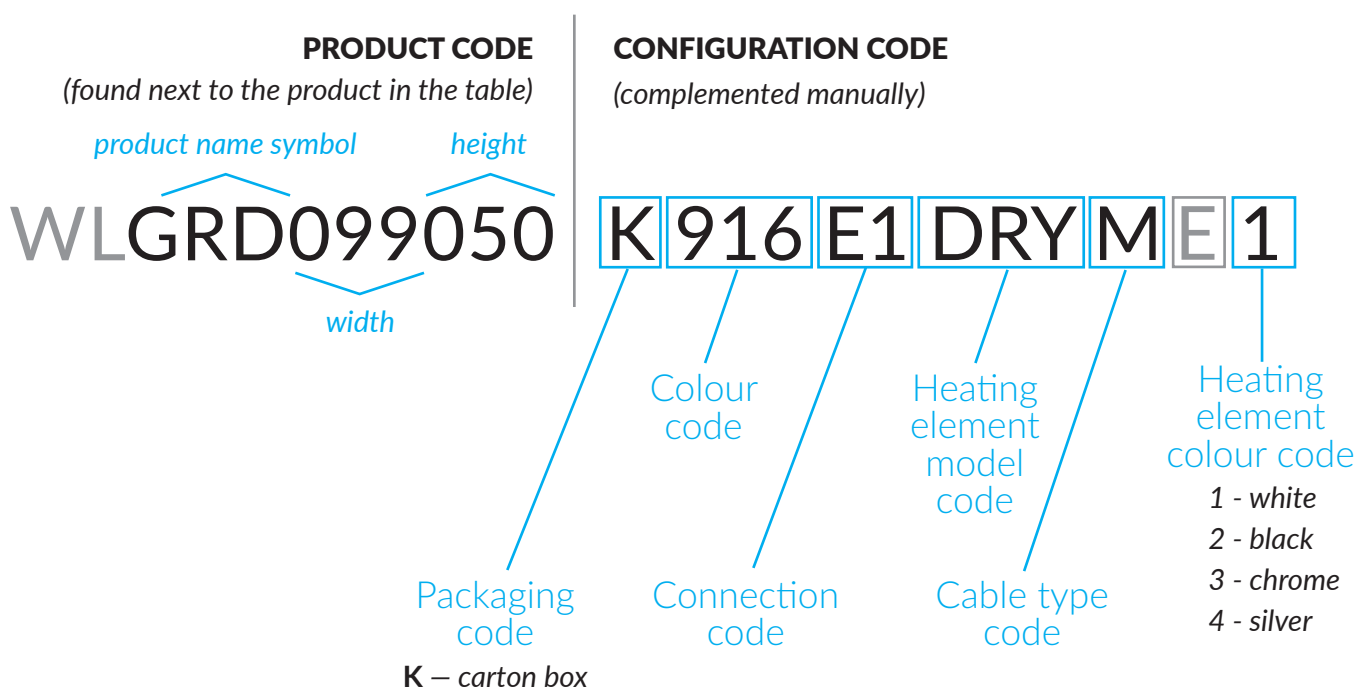

WL – electric towel rail or radiator filled with Oil and fitted with a factory installed heating element

E – the epoxy primer (additional coating increases the corrosion resistance of the product). The extra charge for the epoxy coating is 150 PLN net. In case you don't want the epoxy coating, the "E" should be replaced with an "X".