

# P15J

## Condensate Atomization Pump

### Operation Manual

Please follow the below installation procedures if the reservoir need external usage

1. Remove the front cover
2. Put the signal line and inlet hose enter the main body



- 1 Rubber sleeve
- 2 Pagoda joint
- 3 Signal line
- 4 Inlet hose

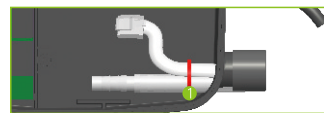

- 1 Fasten with tie-wrap



- 1 Stopper



- 4. Connect with inlet hose

- 1 Air-conditioner drainage hose

#### Power line and signal line

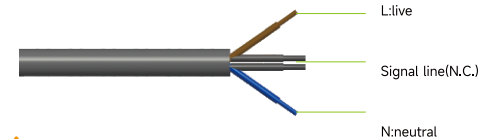

#### Attention

1. Be sure voltage consistent with the product identification, then connect with the power
2. Connect the signal line with AC's Liquid Level Switch(N.C.), it will stop the AC when the drainage have problem

#### Warning

Please pay attention to distinguish the power cord from the signal line, incorrect wiring will cause damage to the pump.  
Ensure the voltage is consistent with pump.

#### 5. Product's principle

1. The yellow light is always on when power on
2. When the water level reaches the start position, the pump start working with the green light is on.
3. When the water level drops to the stop position, the pump stop working with the red light is off.
4. If the water level reaches the alarm level, the red light will be on and the buzzer will sound for 3 minutes. If the system is connected to the signal line, the power supply of the air conditioner will be cut off at the same time. The power supply will be restored and the red light will be off at the same time when the pump resume normal working

# P15J

## Condensate Atomization Pump

### Operation Manual

Thank you for buying WIPCOOL condensate atomization pump, we are dedicated to provide you with high quality products.

Please check if your ordered goods in good shipment condition, with the correct accessories, any damage during transportation, please contact us or the local distributors in time if you find any problems.

If there is any change in the product (including the specification), we won't inform any more.

#### 1. Instructions for use

- ① The product should be installed horizontally to avoid tilting;
- ② Non professional personnel should not install it to avoid danger.
- ③ It is strictly prohibited that the water inflow is greater than the pump's max flow rate, otherwise it will easily cause the motor working continuously and failure.

#### Attention

1. the max suction lift is only 1.5m, it will failure normal working if over 1.5
2. the condensate water must drop into the reservoir by gravity
3. the pump should be installed under the air-conditioner outdoor unit when pump is used in outdoors.

#### 2. Product diagram

##### Tank Built-in

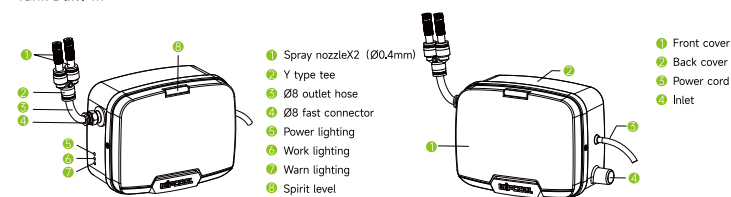

##### Tank External

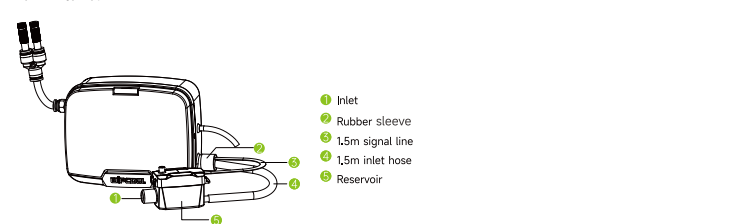

#### 6. Maintenance

##### Attention

Be sure to clean the reservoir and filter every 3 months or more often to avoid the dirt blockage and affect the running

Maintenance steps are as follows

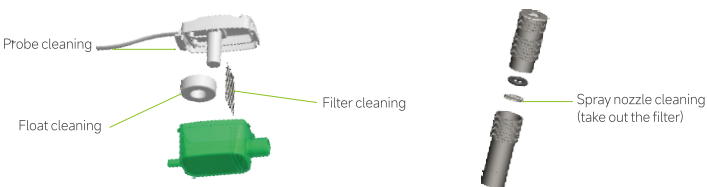

#### When the pump is not used for a long time

please use stoppers to cover the inlet and outlet when pump is not used for a long time



#### 7. Troubleshooting

Problem	Cause	Action
Pump runs all the time	1. Installation is not horizontal	Adjust the pump and tank to be level position
	2. There is sludge inside tank	Clean the inside of tank, probe&float surface
Pump can not self-priming	1. There is dirt inside motor	a. Filling the tank, let motor continue working until the dirt come out the motor b. If still can not solve the problem, replace the motor
	1. Installation is not horizontal	Adjust the tank, check water level
Pump can't start working	2. The power can't reach pump	Check power supply (Yellow light doesn't work) Check if the wiring are loosen (Yellow light is on)
	3. The voltage isn't correct	Check the voltage
	1. The filter is blockage	Clean the reservoir or nozzle's filter

#### 3. Dimension

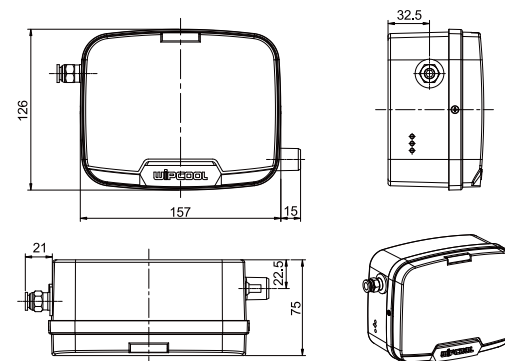

#### TECHNIC DATA

Model	P15J	Reservoir	35ml
Voltage	AC230V ~ /50-60Hz	Mini Splits up to	7.5KW (30000tu/hr)
Flow Rate (nozzle: 0.4mm)	15L/h	Sound level	55dB(A)
Working Pressure	7bar	Ambient Temp	0-50°C

#### 4. Installation Procedure

1. Fasten the hanging panel on the wall, then install the pump



- 1 M4x20 self-tapping screw
- 2 Hanging panel

2. Snap in



- 3 Slot

3. Connect with inlet hose



- 4 Air-conditioner drainage hose

4. Connect with outlet hose and spray nozzle



- 5 Spray nozzle

#### More Condensate Pump For Choice:



YouTube [www.wipcool.com](http://www.wipcool.com)  
Scan us for more details